

CITY *of* PORT ANGELES

Design Manual *for* Wayfinding

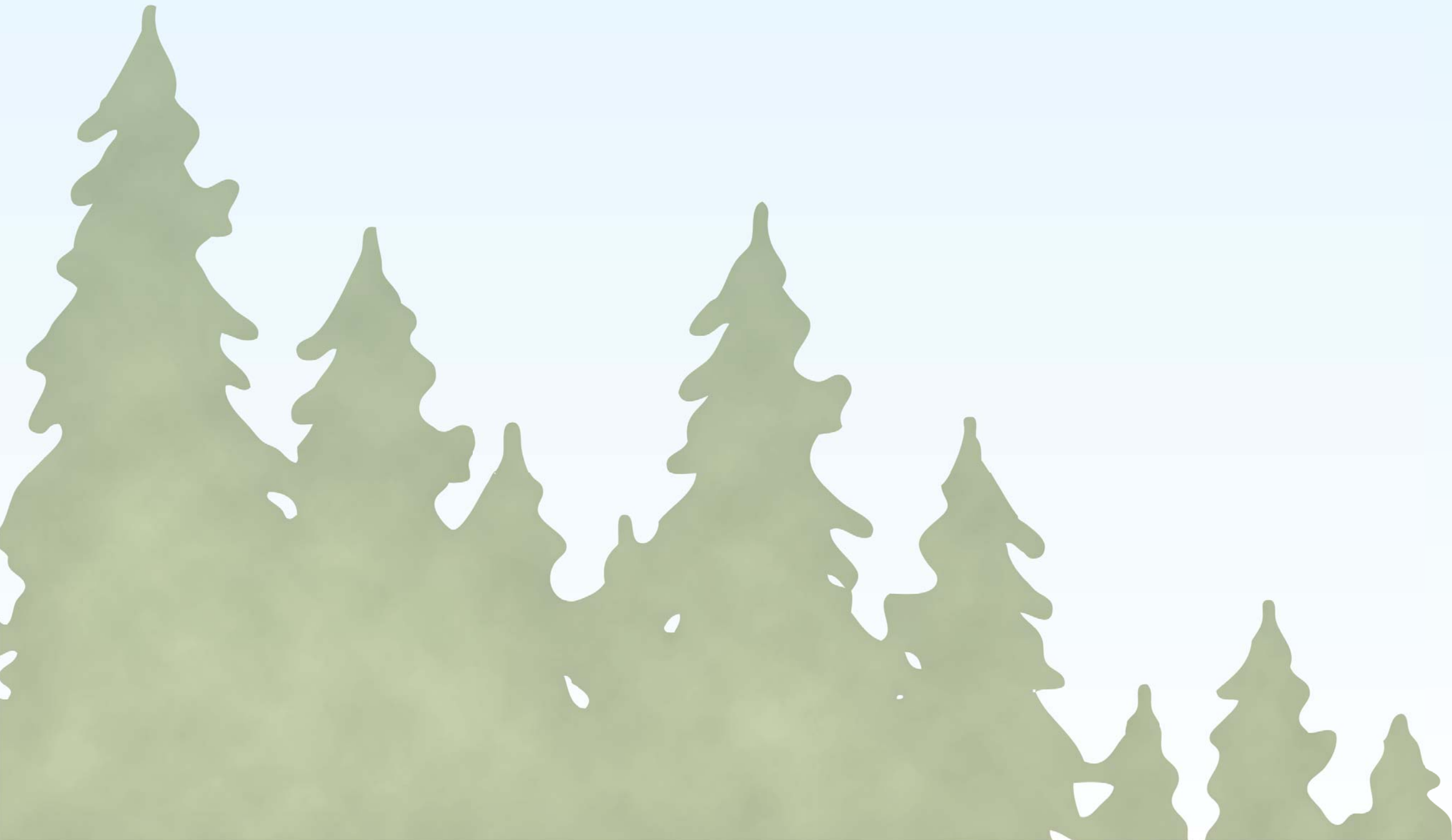





Table of Contents

PROJECT PROGRAM SUMMARY

City of Port Angeles — Revitalization Goals	2
What is Wayfinding?	3
Wayfinding Observations	3
Destinations	4
Sign Design Standards	4

DESIGN INTENT DOCUMENTS

Sign Specifications	6
Wayfinding Palette	7
Sign Details	8
Sign Removal Plan	39
Sign Location Plans	47
Sign Placement Guidelines	67
Destination Matrix	68
Sign Messages	70
Sign Quantities	79
Tips for Success	80

Project Program Summary

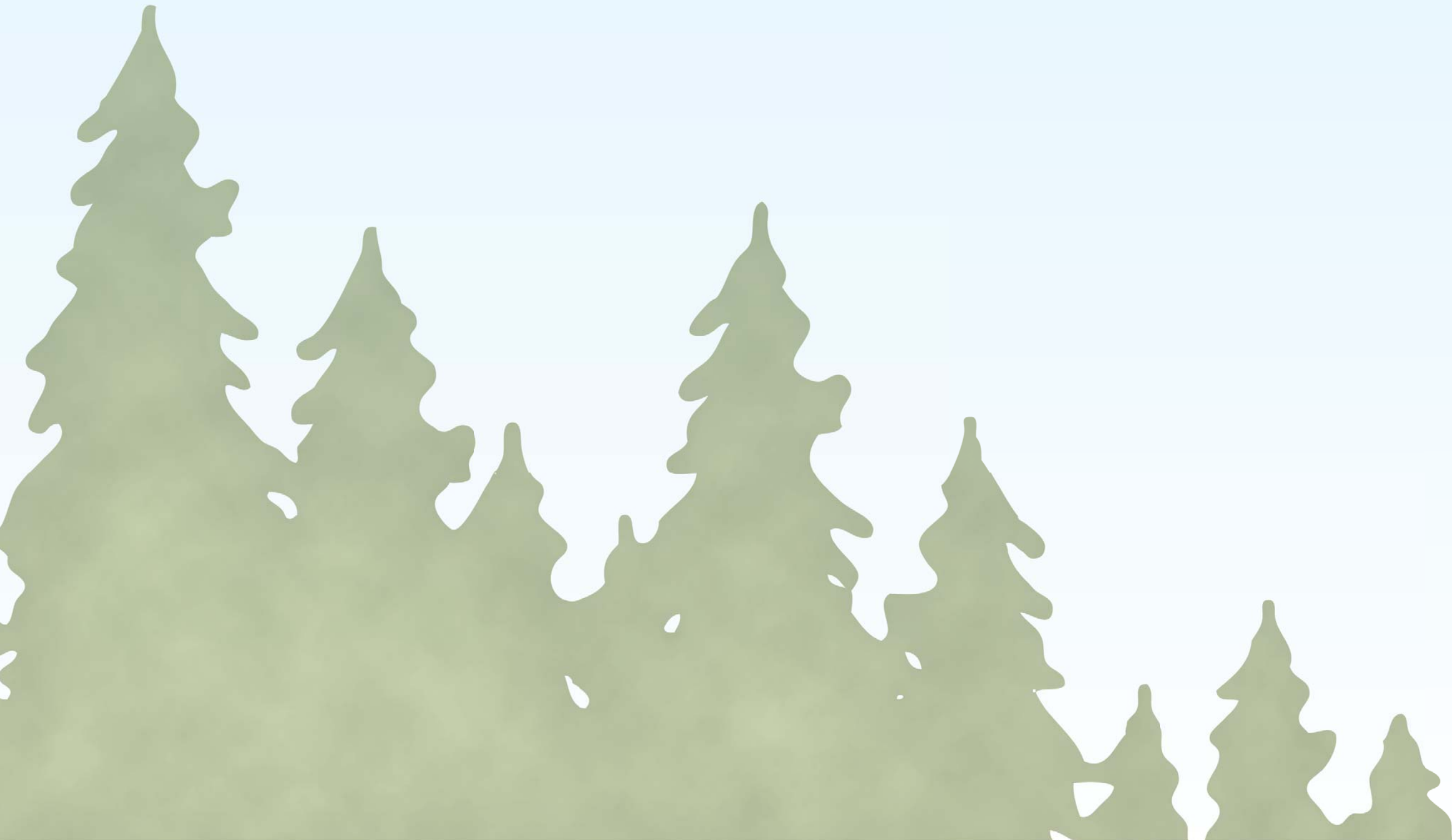



REVITALIZATION GOALS

Surrounded by its active waterfront and picturesque mountains, the City of Port Angeles is focusing on improving the activity of the waterfront and connecting residents, visitors and businesses to it. The City's vision is to improve accessibility for visitors to Port Angeles as well as open spaces along the waterfront. The downtown vibrancy will be enhanced by building on the existing artistic, cultural and historic elements of Port Angeles, maintaining its quaint, community atmosphere.

An effective wayfinding system throughout Port Angeles will be an integral part of these revitalization goals. It will provide ease of movement within the City, strengthen its identity, and help visitors and residents engage and connect with the region. Improved gateways will create a sense of arrival and celebrate entry into the City while internal directional signage will aid in the branding of the City and contribute to a sense of place and security while providing ease of access.

WHAT IS WAYFINDING?

Wayfinding is the art of using visual information such as signage, maps, landmarks or icons to help navigate pedestrians and vehicles through an unfamiliar and complex environment. These environmental clues direct users to a destination and allow them to experience the site without confusion, creating a positive feeling and a sense of comfort and security.

Unfamiliar environments make special demands on the user. Even the simplest settings can involve a jumble of information that must be sorted through and processed before it can become meaningful. In order to create these meaningful environments, five major components for the wayfinding system must be understood. These components are;

1. **Paths** A user's first experience centers on these channels of movement, primarily in their cars, but also on foot or by bike.
2. **Edges** Either a visible seam, a barrier, or even a pathway, edges create places by making divisions between different parts of the project as well as its outer perimeter.
3. **Districts** Places with an identifiable character visible both as one approaches and once one has entered inside them.
4. **Nodes** Nodes are points of connection, convergence and intersection where the essence of place will concentrate. They are important decision making points.
5. **Landmarks** As physical objects of notable visibility, landmarks create bold first impressions and are increasingly relied upon for orientation and wayfinding success.

Source: Kevin Lynch, *The Image of the City*

WAYFINDING OBSERVATIONS

Users: Who & Why?

The City of Port Angeles benefits from the vibrance of its downtown core which creates a unique and cultural community that attracts residents of Port Angeles, as well as visitors and businesses. Residents and visitors enjoy a variety of shops, restaurants, art galleries and museums as well as lively community events. The City serves as an international gateway since it has the only ferry service in the region to Victoria, British Columbia.

The target audience of the proposed wayfinding system includes:

- Residents visiting the restaurants, shops and art galleries downtown
- Residents and visitors departing and arriving by ferry

- Residents and visitors using the waterfront, especially during annual events
- Tourists visiting parks, museums and other attractions in the area

Common Needs Shared By Multiple Users

Visitors require ease of access to their destination by use of clear communication. These needs include vehicular direction as they enter the downtown, affirmation that they are heading in the correct direction, and clear direction to the actual destination and appropriate parking. Once they have reached a parking facility, the visitors will need direction on a pedestrian level. Effective pedestrian wayfinding not only helps visitors find their destination but also promotes walkability, reduces vehicular traffic demands on streets and increases the patronage of shops and restaurants.

Events patrons have particular needs; a high volume of traffic often present during these events creates confusion for visitors who are already uncertain about where they should go or where they can park. Clear identification of public parking is essential. Additionally, clear identification of event parking as patrons approach an event will reassure the visitor that they are on the right path.

Residents and business owners make decisions of where they settle based on several factors; including the quality of the experience, perception of safety and availability of nearby amenities for themselves, clients and visitors. Making people aware of local cultural and historical institutions, waterfront amenities, and other area attractions adds to the value of the overall city experience.

Existing Sign System

While Port Angeles continues to exude a strong sense of place and regional identity, its context is fraying due to the impact of sign clutter and its disconnection from the waterfront.

The City needs to have a strong sign system that communicates clear information while being flexible and consistent. The current sign system in the City is inconsistent and lacks characteristics necessary to be recognizable and effective. Directional signage is neither consistent nor located in appropriate areas to give a visitor enough information to effectively find their way. There is also no hierarchy established or layering of information on existing signs to support a complete route from route to destination.

A large challenge within the current wayfinding system is the presence of a one-way street system, which creates the need for increased accuracy and additional signage to allow visitors to navigate effectively without having to drive in circles.

Parking Assessment

Public parking in Port Angeles is abundant. Several large public lots are accessible and convenient to shops, restaurants, and government buildings, and there are on-street parking spaces available as well.

The primary challenge with the current parking system is a lack of parking identification. There are surface lots and on-street spaces that are either not marked, or the marking is unclear as to how many hours a visitor can park, etc. Consistency is also a problem; there is not a clear symbol or sign used throughout the downtown to indicate where parking exists, making the spaces that are available less effective.

As Port Angeles continues to attract new residents and visitors, creation of a simple and consistent parking identification brand will be essential. The ease of finding parking is especially important to create a "park once" environment where visitors and residents are encouraged to leave their vehicles and walk to multiple locations.



SIGNAGE AND DESTINATIONS

Signage will play a major role in improving the wayfinding within the City. Gateway entries, vehicular directional, pedestrian directional and parking identification are all integral to create a complete wayfinding system that will provide ease of access throughout the City.

The terminology for each destination should be simple, user-friendly, and memorable. Each message should be consistent in its display from sign to sign and contain no more than twenty characters. This enables each destination to have equal emphasis, proper legibility and proportions.

Due to the number of destinations in the City, it is best to organize these destinations into tiers; this allows us to layer information as a visitor enters the city through a series of decision points. Any attempt to guide to all of the destinations would be impossible due to the size limitations of available sign space and the limitations for a driver or pedestrian to comprehend a sign. Because of these limitations, two levels of signs are proposed: vehicular directional and pedestrian directional.

Criteria List for Destinations

In order for a destination to be included on vehicular directional signs in the City wayfinding system, they should meet the following criteria and each destination must be approved by the City:

- Be a public/non-profit facility
- Be a public safety facility (hospital, police, etc.)
- Be located nearby or within the boundaries of the wayfinding study area
- Be a government building (city, county, or state)
- Be one of the destinations as listed below.

<u>List of Top Destinations</u>	<u>Suggested Abbreviations</u>
Downtown	Downtown
Ferry	Ferry
National Park	National Park
City Hall	City Hall
Airport	Airport
Lincoln Park	Lincoln Park
Marina	Marina
Boat Launch	Boat Launch
Visitor Center	Visitor Ctr

Feiro Marine Life Center	Marine Ctr
Clallum County Courthouse	Courthouse
Civic Field	Civic Field
Ediz Hook	Ediz Hook
Heritage Center	Heritage Ctr
Fine Arts Center	Fine Arts Ctr
Peninsula College	College
Coast Guard	Coast Guard
Historic District	Historic Dist
Clallum County Fairgrounds	Fairgrounds
Composite Campus	Campus
Peninsula High School	High School
Carnegie Library	Carnegie
Swimming Pool	Pool
City Pier	City Pier
Shopping	Shopping
Dining/Coffee	Dining
Lodging	Lodging
Waterfront Trail	Trail
Kayak Launch	Kayak Launch
Laurel Stairs	Laurel Stairs

Super Destinations

A “Super Destination” is a major attractor facility that is directed to as a priority from each major access point (node) into the City. All other vehicular wayfinding destinations are directed to locally. The sign system is flexible enough to contain three “Super Destinations”, which should be evaluated during the wayfinding process to determine if a new destination needs to be added or if others need to be removed.

<u>Super Destinations</u>	<u>Suggested Abbreviations</u>
Downtown	Downtown
Ferry	Ferry
National Park	National Park

SIGN DESIGN

Sign Design

Signage should present a consistent message. For this reason, a consistent palette of colors should be used throughout the sign system. Using the same colors increases legibility of the wayfinding system, enabling faster recognition and expectations of the signs as a driver approaches. Since the sign system needs to compete with the urban environment and landscape, the color choices for signs must be strong but not overwhelming to the streetscape environment. The following guidelines should be followed to have a legible and functional wayfinding system.

Finish and Contrast

The format we recommend adheres to the Federal Americans with Disabilities Act (ADA) minimum requirements regarding presentation of information on signs used to provide direction or identify spaces. Letter characters and backgrounds for both identification and directional signs must have a non-glare finish. Characters and symbols will have at least 70% contrast with their background. Light characters on a dark background read more easily, especially at night. High intensity reflective vinyl shall be used for all vehicular sign messaging.

Cap Height

Given the prevailing traffic speeds in the area, vehicular sign messages should have a minimum 4.5-inch cap height for roads 25 mph or less and 6.0-inch cap height for roads greater than 25 mph.

Number of Sign Messages

Given the proposed letter height for the speeds encountered, we propose a maximum of three one-line messages per vehicular guide sign.

Organization of Messaging

The destinations shall be ordered to be consistent with the WSDOT policies on directional guide signs. This message order is destinations ahead listed first, left turning listed second and right turning listed last. The organization within this group should be closest destination first.

Sign Clearance

The Manual for Uniform Traffic Control Devices (MUTCD) sets specific minimum height for vehicular directional signs as 84” from the ground to the bottom of the sign panel. In addition to these requirements we recommend 24” clearance from side of curb to edge of sign to prevent clipping from traffic. Specific attention should be given to the vertical obstructions such as signs, trees, and light poles when locating a sign.

Design Intent Documents

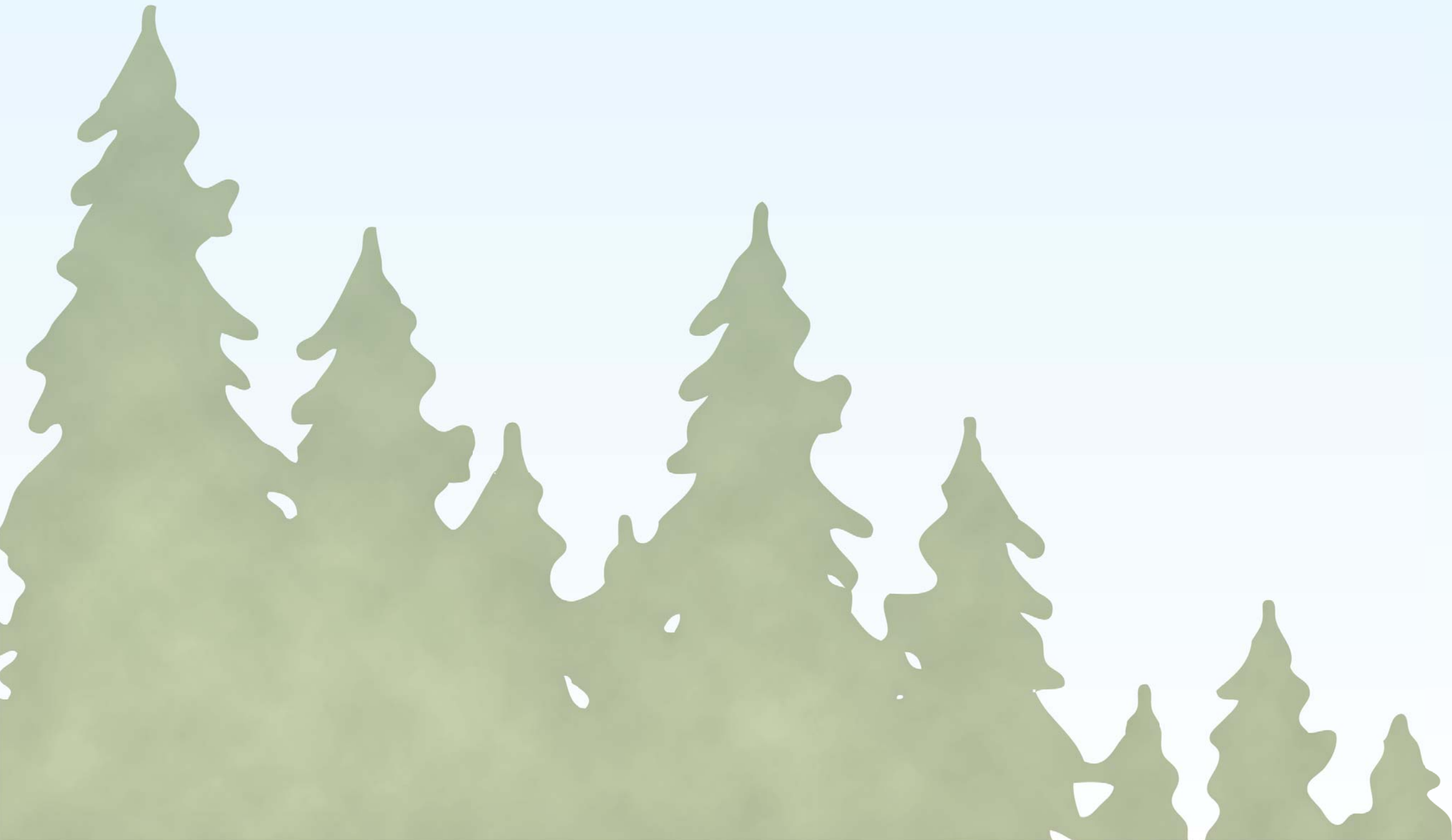

Wayfinding System

Specifications
10330217.01
City of Port Angeles, Washington

Description:
Specifications

Original Issue Date: 2011.01.07

Revisions: 2011.02.08

These drawings express visual design intent only. Final engineering, materials, and fabrication shall remain the responsibility of the fabricator.

The content of this document is subject to the design intent requirements outlined in the following sections: Fabricator Performance & Material Requirements, Quantities & Submittals, Materials & Finishes, and Fonts & Symbols.

Contact:
Environmental Graphics/Wayfinding
AECOM
407-843-6552
150 N Orange Avenue, Suite 200
Orlando, Florida 32801

Project Team:
JMM
SPC
DMH

Drawn By: SPC

Colors:



C-1 White



C-2 Green



C-3 Gray

Arrowforms:



Artwork:



Fonts:

Futura

ABCDEFGHIJKLMNOPQRSTUVWXYZ
Uppercase

abcdefghijklmnopqrstuvwxyz1234567
Lowercase

Gotham - Bold

ABCDEFGHIJKLMNOPQRSTUVWXYZ
Uppercase

abcdefghijklmnopqrstuvwxyz1234567890
Lowercase

Quality Assurance

- A. Coordinate final sign locations with the Designer.
- B. Provide a five-year warranty on the sign construction, structures, and paint finishes.

Project Conditions

- A. Field Measurements: Take field measurements prior to preparation of shop drawings and fabrication to ensure proper fitting. Verify location of all sign locations. Show recorded measurements in final shop drawings. Coordinate fabrication schedule with construction progress to avoid delay.
- B. Fabricator shall create a detailed sign location plan with proposed sign location site photos and dimensions from curb and edge of pavement.

Performance Requirements

- A. All signage shall be of top quality workmanship and materials, and be free of defects. Defects are defined to include delamination, abnormal deterioration, fading and discoloration, weathering, failure of securing to substrates indicated, cracking, bubbles, corrosion or coating damage, or visible scratches on surfaces.
- B. Signage shall not bear manufacturer's code or other identifying marks on any area or part that may be visible in the normal positioning, attitude, or use of the sign. Code may require sign permits to be posted on each sign.
- C. The drawings are diagrammatic and indicate the aesthetic of "design intent" only. Details shown are intended as a guide for the interfacing of adjacent surfaces. Any changes made to the design for structural reasons or value engineering shall be coordinated with the Designer.
- D. The sign fabricators shall ensure that the design of all support substrates and structures are adequate for the performance of all work required.
- E. The fabricator shall be familiar with proper construction methods and installation of all items, shall have at least ten years of experience, and shall have successfully completed at least six similar projects.
- F. This specification makes no attempt to consider all construction requirements that may apply.
- G. The Designer reserves the right to visit the plant where fabrication will occur. The contractor shall submit proof of previous projects to illustrate manufacturing capabilities.
- H. Foundation and sign panels must be designed to withstand wind loads specified in the WSDOT Standard Index. Testing of site soils including engineering and compaction is the responsibility of the fabricator.
- I. The fabricator shall ensure the sign designs, sign structures, wind load calculations and break-away foundations are signed and sealed by a Professional Engineer (P.E.) licensed in the state of Washington.

Signing and Graphic Submittals

- A. Prior to commencement of work, the fabricator shall provide scaled drawings of all elements. Shop drawings shall show all suggested text styles, dimensions, details of construction, materials, technical data, and installation instructions for each type of sign required. The sign contractor is to provide wind load calculations and foundation designs and show anchorages and accessory items.
 - 1. Submit proofs of artwork and symbols of actual painted aluminum for each color specified.
 - 2. Submit prototype samples and color-match samples.
 - 3. Submit complete layout of text and Client-supplied graphics for review prior to start of fabrication. If more than one supplier's cut will be used, submit each cut for review.
- B. Samples shall be fabricated with colors and protective finishes required.
- C. Submit fabrication schedule.
- D. Submit shop drawings.
- E. Submit signage schedule: The signage schedule is a consolidated reference that gives the location, sign type, copy, surface, and/or mounting, and information that is not conducive to exclusive categorization. The fabricator shall submit scaled layout for each sign face for copy, format, and spacing approval.

Manufacturer Contact Information:

Avery Dennison 250 Chester Street #6 Painesville, OH 44077 1-800-282-8379 www.averydennison.com	3M 3M Center Bldg 220 St. Paul, MN 55144 1-800-374-6772 www.3Mgraphics.com	Matthews Paint 760 Pittsburgh Drive Delaware, OH 43015 1-800-323-6593 www.corporateportal.ppg.com	Folia (Phenolic Resin Panel) 110 Wellington St Huntingdon QC Canada, JOS 1H0 1-888-264-6122 www.folia.ca
---	--	---	---

WAYFINDING SIGN PALETTE



WSDOT
Vehicular Directional

Vehicular Directional

Pedestrian Directional

Parking ID
D-1

Parking ID with
Pedestrian Map
D-2

Pedestrian
Kiosk Map

Historic
District

Tsunami
Evacuation
Route
G-1

Tsunami
Evacuation
Route
G-2

Wayfinding System - Sign Details

Sign Type A
10330217.01
City of Port Angeles, Washington

Scale: 1/2" = 1'

Note: Drawing scale shown on plans is accurate for full size plans only. AECOM is not responsible for scale discrepancies caused by reduced size plans.

Description:
WSDOT Vehicular Directional

Original Issue Date: 2011.01.07

Revisions: 2011.01.28
2011.03.01
2011.05.06

These drawings express visual design intent only. Final engineering, materials, and fabrication shall remain the responsibility of the fabricator.

The content of this document is subject to the design intent requirements outlined in the following sections: Fabricator Performance & Material Requirements, Quantities & Submittals, Materials & Finishes, and Fonts & Symbols.

Contact:
Environmental Graphics/Wayfinding
AECOM
407-843-6552
150 N Orange Avenue, Suite 200
Orlando, Florida 32801

Project Team:
JMM
SPC
DMH

Drawn By: SPC

Front View

Back View

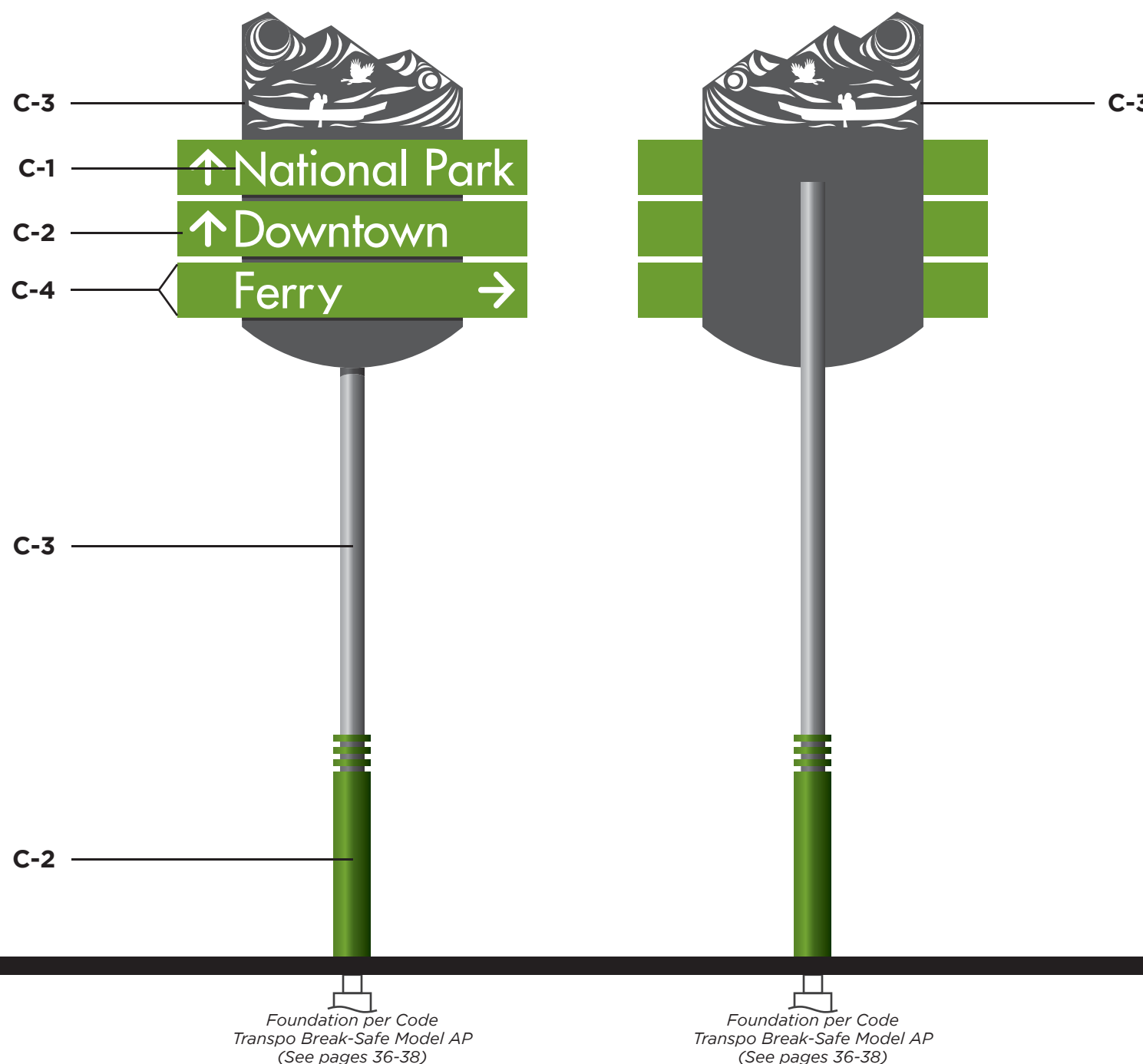

C-1	White Avery HV 1200-101-R Opaque Retro-Reflective White
C-2	Green PMS 377C MP00056 (Green Herb)
C-3	Dark Gray PMS 9C (Cool Gray) MP11490 (Vanadium Grey)
C-4	Matthews Anti-Graffiti Clear Coat <i>*applied on all painted surfaces</i>

DIMENSIONS

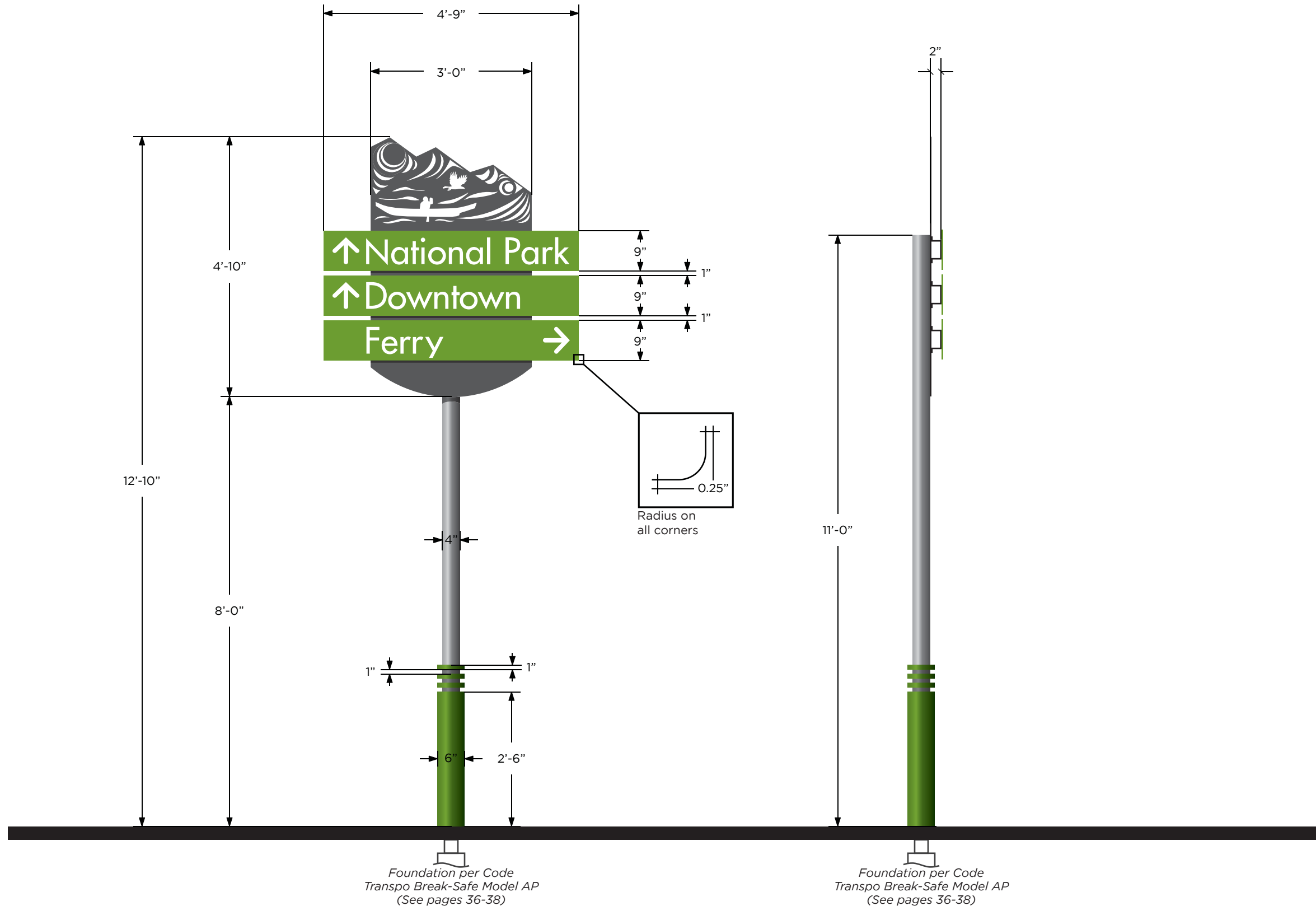

Wayfinding System - Sign Details

Sign Type A
10330217.01
City of Port Angeles, Washington

Scale: 1/2" = 1'

Note: Drawing scale shown on plans is accurate for full size plans only. AECOM is not responsible for scale discrepancies caused by reduced size plans.

Description:
WSDOT Vehicular Directional

Original Issue Date: 2011.01.07

Revisions: 2011.01.28
2011.03.01
2011.05.06

These drawings express visual design intent only. Final engineering, materials, and fabrication shall remain the responsibility of the fabricator.

The content of this document is subject to the design intent requirements outlined in the following sections: Fabricator Performance & Material Requirements, Quantities & Submittals, Materials & Finishes, and Fonts & Symbols.

Contact:
Environmental Graphics/Wayfinding
AECOM
407-843-6552
150 N Orange Avenue, Suite 200
Orlando, Florida 32801

Project Team:
JMM
SPC
DMH

Drawn By: SPC

MATERIALS

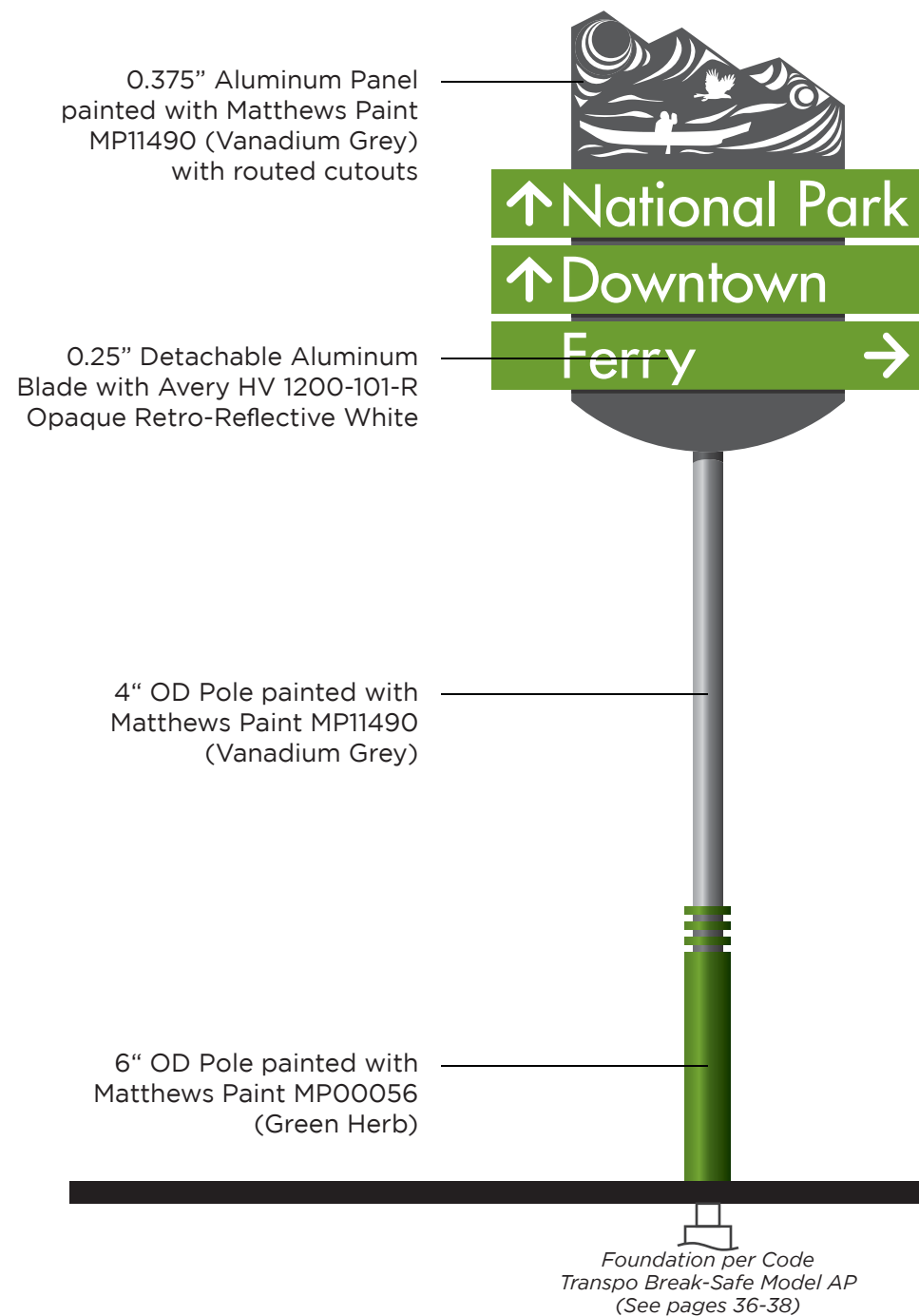

ASSEMBLY

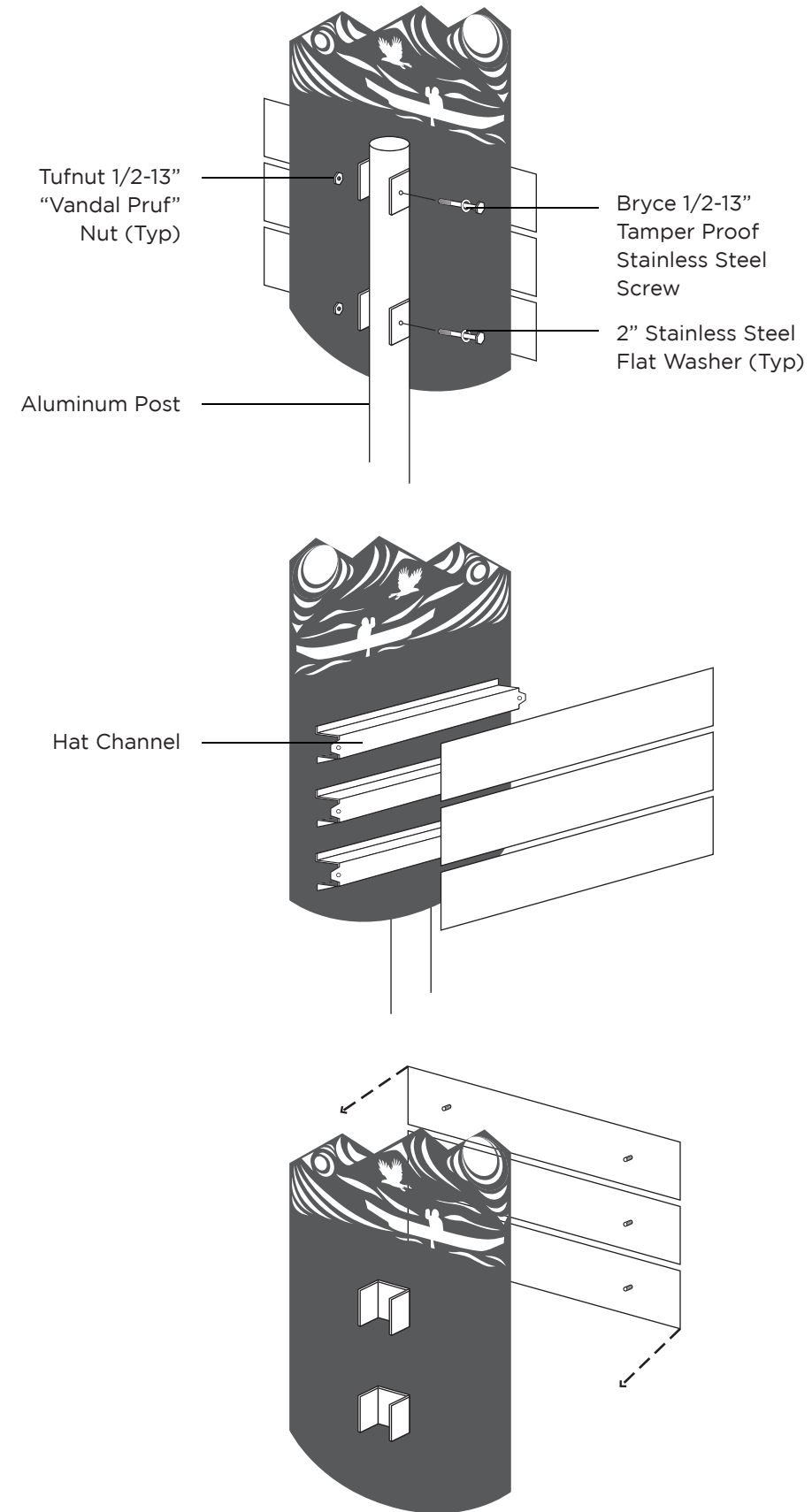

Wayfinding System - Sign Details

Sign Type A
10330217.01
City of Port Angeles, Washington

Scale: 1/2" = 1'

Note: Drawing scale shown on plans is accurate for full size plans only. AECOM is not responsible for scale discrepancies caused by reduced size plans.

Description:
WSDOT Vehicular Directional

Original Issue Date: 2011.01.07

Revisions: 2011.01.28
2011.03.01
2011.05.06

These drawings express visual design intent only. Final engineering, materials, and fabrication shall remain the responsibility of the fabricator.

The content of this document is subject to the design intent requirements outlined in the following sections: Fabricator Performance & Material Requirements, Quantities & Submittals, Materials & Finishes, and Fonts & Symbols.

Contact:
Environmental Graphics/Wayfinding
AECOM
407-843-6552
150 N Orange Avenue, Suite 200
Orlando, Florida 32801

Project Team:
JMM
SPC
DMH

Drawn By: SPC

Wayfinding System - Sign Details

Sign Type A
10330217.01
City of Port Angeles, Washington

Scale: NTS

Note: Drawing scale shown on plans is accurate for full size plans only. AECOM is not responsible for scale discrepancies caused by reduced size plans.

Description:
WSDOT Vehicular Directional

Original Issue Date: 2011.01.07

Revisions: 2011.01.28
2011.03.01

These drawings express visual design intent only. Final engineering, materials, and fabrication shall remain the responsibility of the fabricator.

The content of this document is subject to the design intent requirements outlined in the following sections: Fabricator Performance & Material Requirements, Quantities & Submittals, Materials & Finishes, and Fonts & Symbols.

Contact:
Environmental Graphics/Wayfinding
AECOM
407-843-6552
150 N Orange Avenue, Suite 200
Orlando, Florida 32801

Project Team:
JMM
SPC
DH

Drawn By: Suchada Cartolano

NOTE: Digital artwork will be supplied by Client.
Do not recreate artwork.



↑ National Park

↑ Downtown

Ferry →

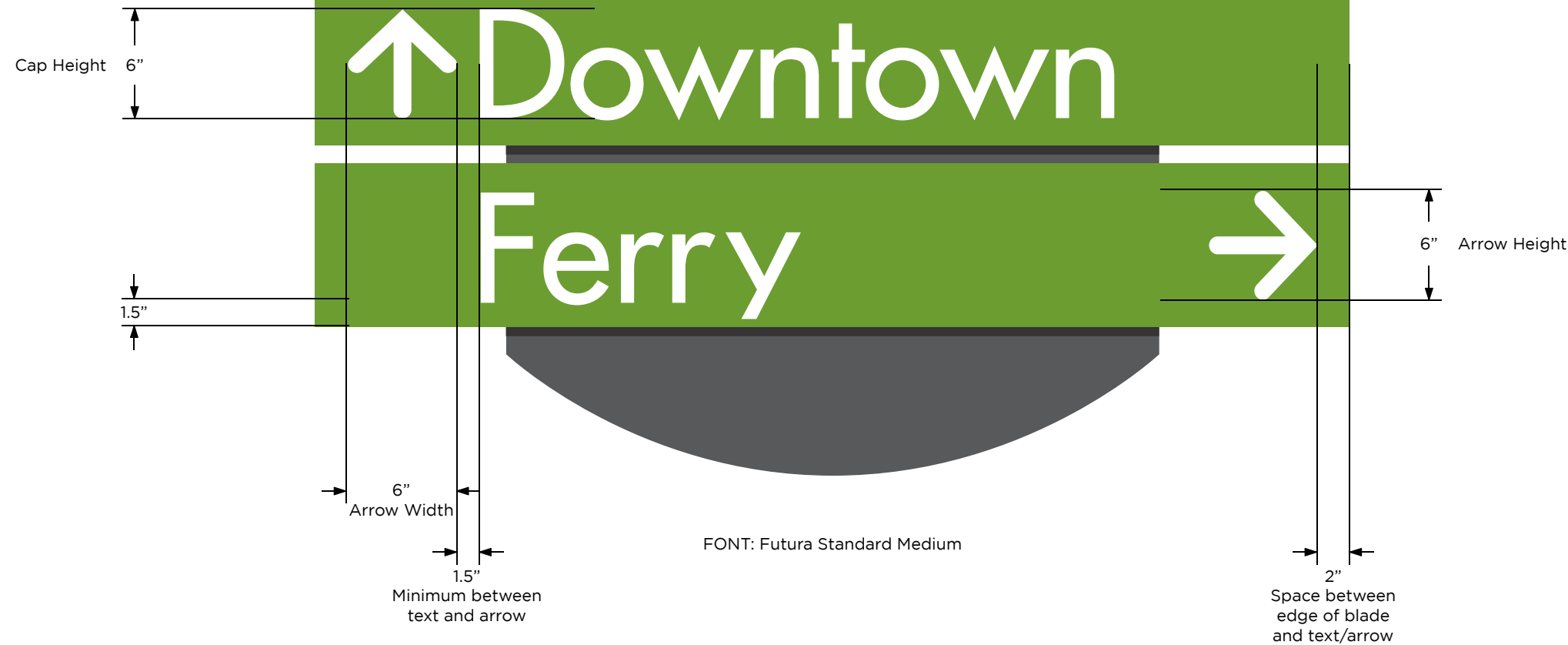

FONT: Futura Standard Medium

Wayfinding System - Sign Details

Sign Type B
10330217.01
City of Port Angeles, Washington

Scale: 1/2" = 1'

Note: Drawing scale shown on plans is accurate for full size plans only. AECOM is not responsible for scale discrepancies caused by reduced size plans.

Description:
Vehicular Directional

Original Issue Date: 2011.01.07

Revisions: 2011.01.28 2011.05.06
2011.02.08
2011.03.02

These drawings express visual design intent only. Final engineering, materials, and fabrication shall remain the responsibility of the fabricator.

The content of this document is subject to the design intent requirements outlined in the following sections: Fabricator Performance & Material Requirements, Quantities & Submittals, Materials & Finishes, and Fonts & Symbols.

Contact:
Environmental Graphics/Wayfinding
AECOM
407-843-6552
150 N Orange Avenue, Suite 200
Orlando, Florida 32801

Project Team:
JMM
SPC
DMH

Drawn By: SPC

Front View

Back View

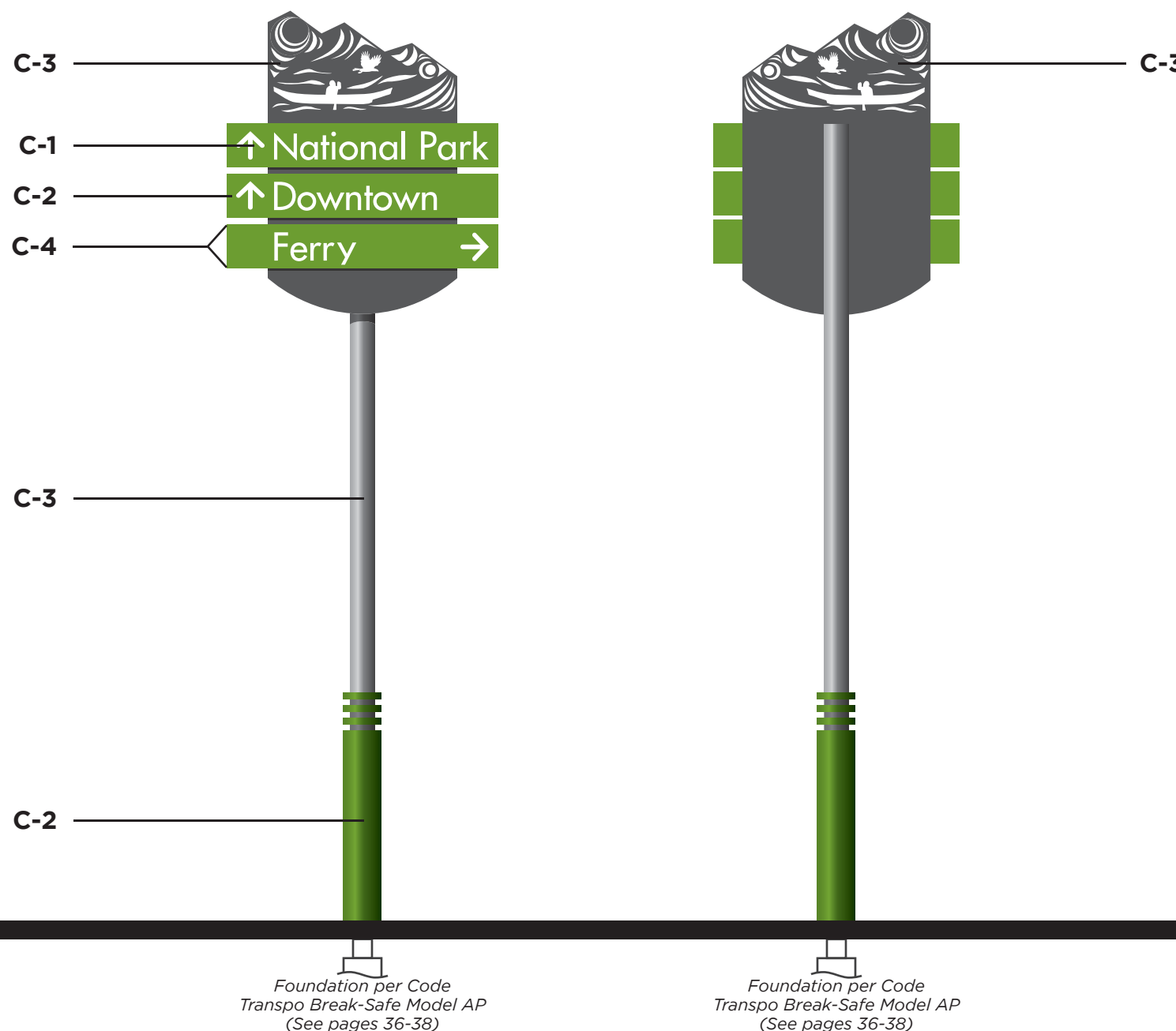

C-1	White Avery HV 1200-101-R Opaque Retro-Reflective White
C-2	Green PMS 377C MP00056 (Green Herb)
C-3	Dark Gray PMS 9C (Cool Gray) MP11490 (Vanadium Grey)
C-4	Matthews Anti-Graffiti Clear Coat <i>*applied on all painted surfaces</i>

Foundation per Code
Transpo Break-Safe Model AP
(See pages 36-38)

Foundation per Code
Transpo Break-Safe Model AP
(See pages 36-38)

DIMENSIONS

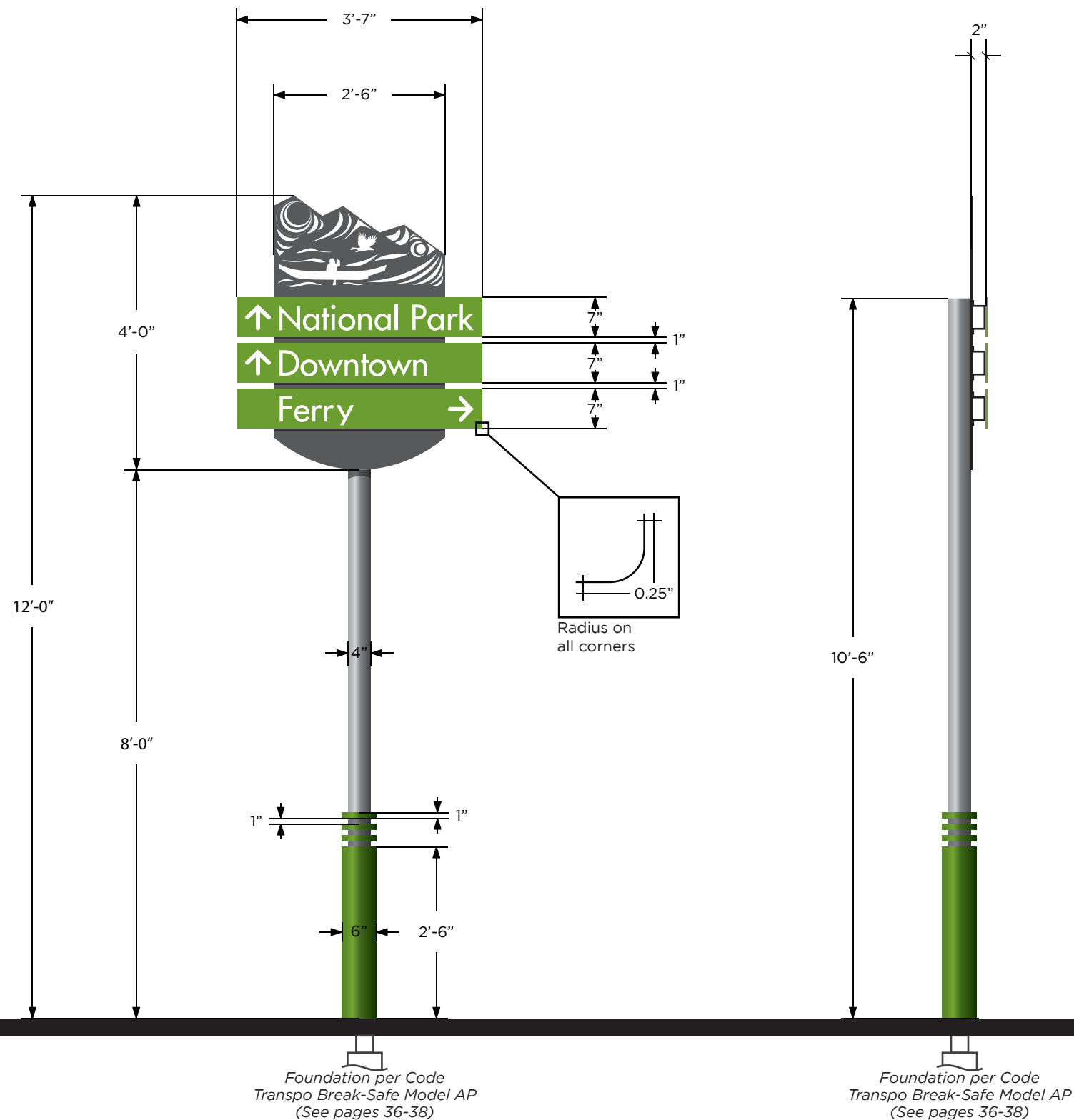

Wayfinding System - Sign Details

Sign Type B
10330217.01
City of Port Angeles, Washington

Scale: 1/2" = 1'

Note: Drawing scale shown on plans is accurate for full size plans only. AECOM is not responsible for scale discrepancies caused by reduced size plans.

Description:
Vehicular Directional

Original Issue Date: 2011.01.07

Revisions: 2011.01.28 2011.05.06
2011.02.08
2011.03.02

These drawings express visual design intent only. Final engineering, materials, and fabrication shall remain the responsibility of the fabricator.

The content of this document is subject to the design intent requirements outlined in the following sections: Fabricator Performance & Material Requirements, Quantities & Submittals, Materials & Finishes, and Fonts & Symbols.

Contact:
Environmental Graphics/Wayfinding
AECOM
407-843-6552
150 N Orange Avenue, Suite 200
Orlando, Florida 32801

Project Team:
JMM
SPC
DMH

Drawn By: SPC

MATERIALS

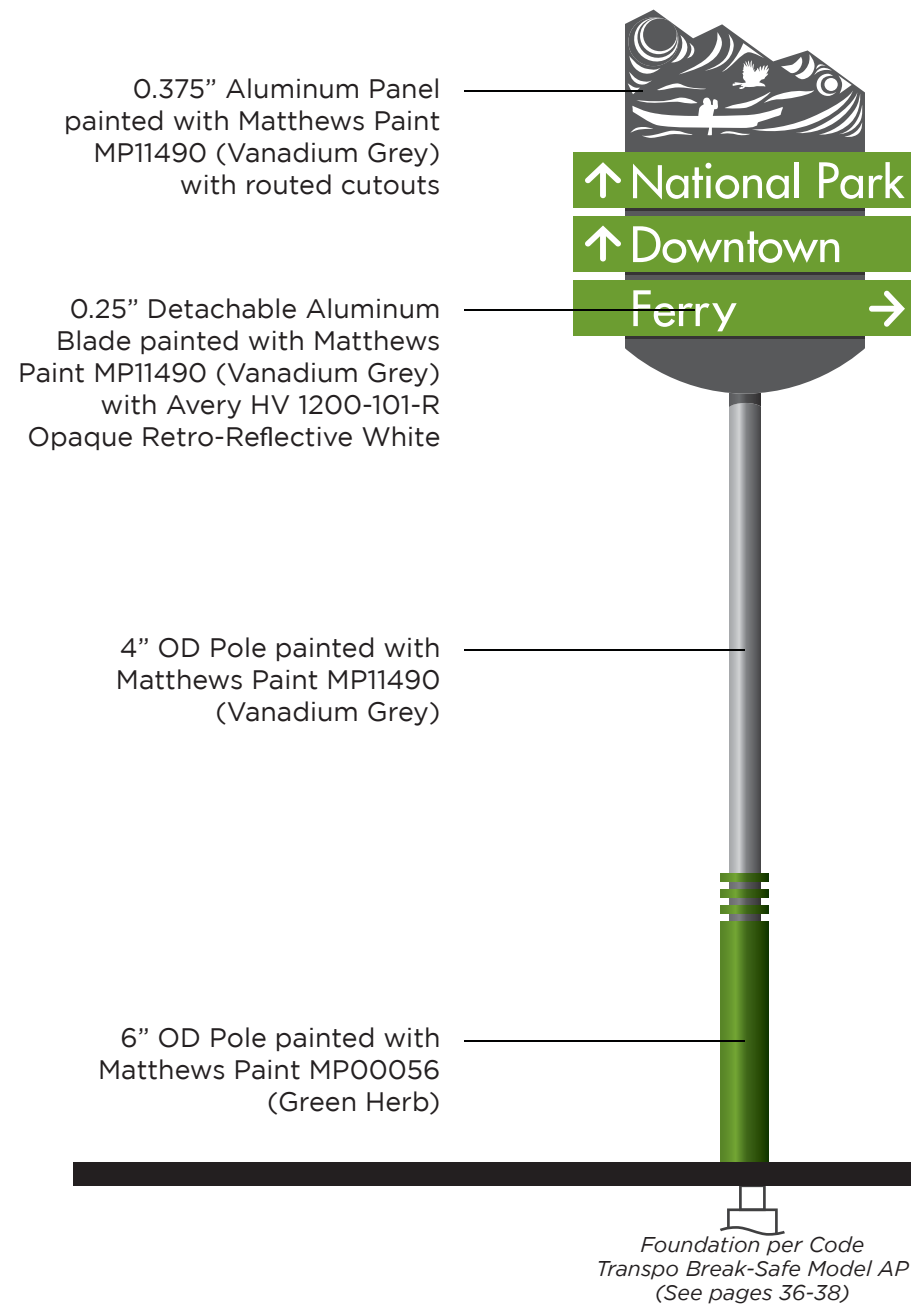

ASSEMBLY

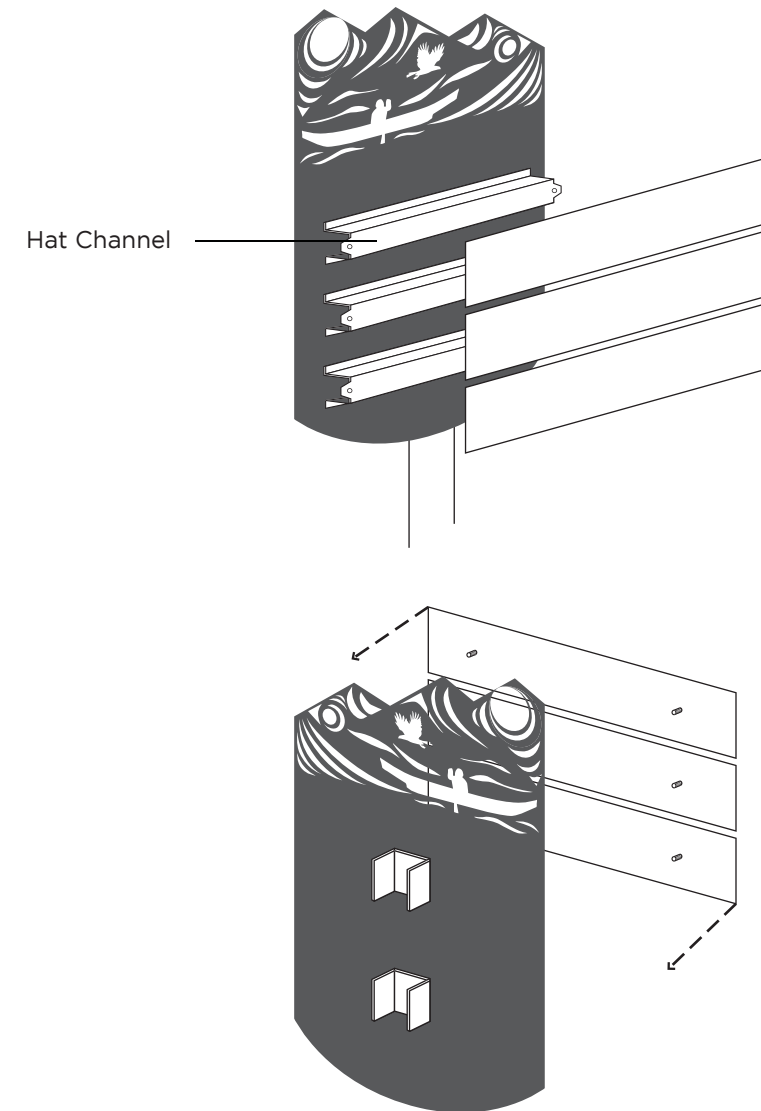
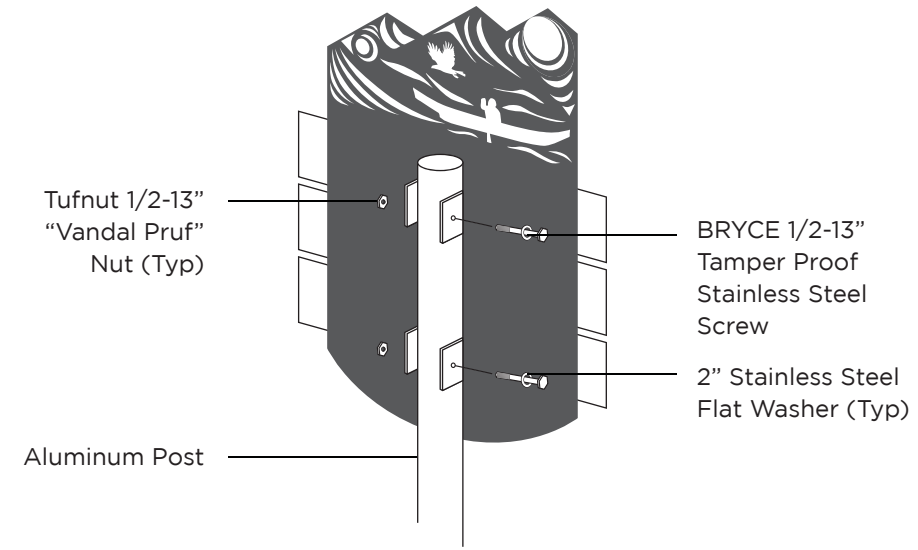

Wayfinding System - Sign Details

Sign Type B
10330217.01
City of Port Angeles, Washington

Scale: 1/2" = 1'

Note: Drawing scale shown on plans is accurate for full size plans only. AECOM is not responsible for scale discrepancies caused by reduced size plans.

Description:
Vehicular Directional

Original Issue Date: 2011.01.07

Revisions: 2011.01.28 2011.05.06
2011.02.08
2011.03.02

These drawings express visual design intent only. Final engineering, materials, and fabrication shall remain the responsibility of the fabricator.

The content of this document is subject to the design intent requirements outlined in the following sections: Fabricator Performance & Material Requirements, Quantities & Submittals, Materials & Finishes, and Fonts & Symbols.

Contact:
Environmental Graphics/Wayfinding
AECOM
407-843-6552
150 N Orange Avenue, Suite 200
Orlando, Florida 32801

Project Team:
JMM
SPC
DMH

Drawn By: SPC

NOTE: Digital artwork will be supplied by Client.
Do not recreate artwork.



↑ National Park

↑ Downtown

Ferry →

Cap Height 4.5"

1.25"

4.5" Arrow Height

4.5" Arrow Width

1.5" Minimum between text and arrow

FONT: Futura Standard Medium

1.5" Space between edge of blade and text/arrow

Wayfinding System - Sign Details

Sign Type B
10330217.01
City of Port Angeles, Washington

Scale: NTS

Note: Drawing scale shown on plans is accurate for full size plans only. AECOM is not responsible for scale discrepancies caused by reduced size plans.

Description:
Vehicular Directional

Original Issue Date: 2011.01.07

Revisions: 2011.01.28
2011.02.08
2011.03.02

These drawings express visual design intent only. Final engineering, materials, and fabrication shall remain the responsibility of the fabricator.

The content of this document is subject to the design intent requirements outlined in the following sections: Fabricator Performance & Material Requirements, Quantities & Submittals, Materials & Finishes, and Fonts & Symbols.

Contact:
Environmental Graphics/Wayfinding
AECOM
407-843-6552
150 N Orange Avenue, Suite 200
Orlando, Florida 32801

Project Team:
JMM
SPC
DH

Drawn By: Suchada Cartolano

Wayfinding System - Sign Details

Sign Type C
10330217.01
City of Port Angeles, Washington

Scale: 1/2" = 1'

Note: Drawing scale shown on plans is accurate for full size plans only. AECOM is not responsible for scale discrepancies caused by reduced size plans.

Description:
Pedestrian Directional

Original Issue Date: 2011.01.07

Revisions: 2011.02.08
2011.05.06

These drawings express visual design intent only. Final engineering, materials, and fabrication shall remain the responsibility of the fabricator.

The content of this document is subject to the design intent requirements outlined in the following sections: Fabricator Performance & Material Requirements, Quantities & Submittals, Materials & Finishes, and Fonts & Symbols.

Contact:
Environmental Graphics/Wayfinding
AECOM
407-843-6552
150 N Orange Avenue, Suite 200
Orlando, Florida 32801

Project Team:
JMM
SPC
DMH

Drawn By: SPC

Front View

Back View

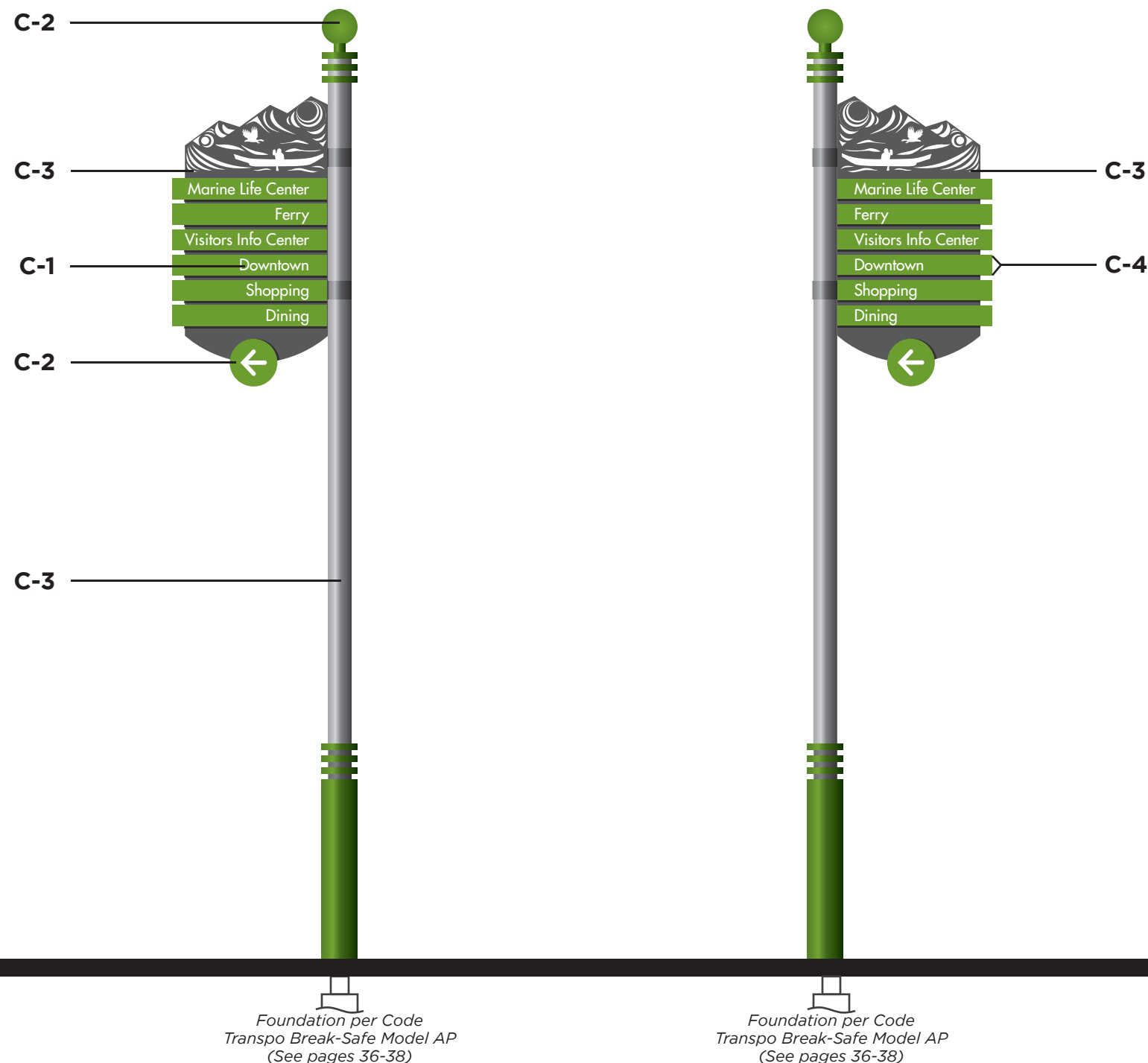

- C-1** White
Avery HV 1200-101-R Opaque
Retro-Reflective White
- C-2** Green
PMS 377C
MP00056 (Green Herb)
- C-3** Dark Gray
PMS 9C (Cool Gray)
MP11490 (Vanadium Grey)
- C-4** Matthews Anti-Graffiti
Clear Coat
*applied on all painted
surfaces

Foundation per Code
Transpo Break-Safe Model AP
(See pages 36-38)

Foundation per Code
Transpo Break-Safe Model AP
(See pages 36-38)

DIMENSIONS

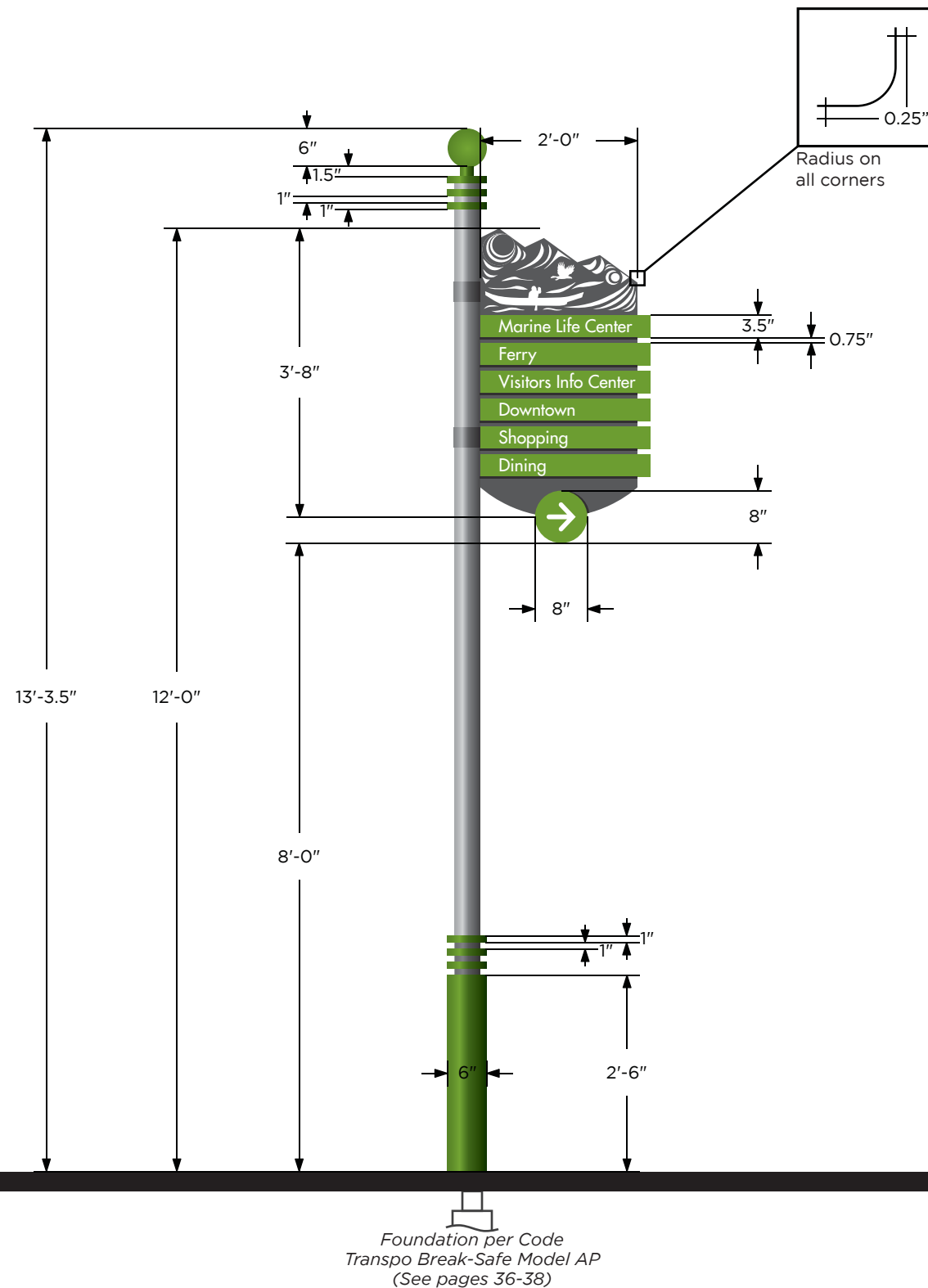

Wayfinding System - Sign Details

Sign Type C
 10330217.01
 City of Port Angeles, Washington

Scale: 1/2" = 1'

Note: Drawing scale shown on plans is accurate for full size plans only. AECOM is not responsible for scale discrepancies caused by reduced size plans.

Description:
 Pedestrian Directional

Original Issue Date: 2011.01.07

Revisions: 2011.02.08
 2011.05.06

These drawings express visual design intent only. Final engineering, materials, and fabrication shall remain the responsibility of the fabricator.

The content of this document is subject to the design intent requirements outlined in the following sections: Fabricator Performance & Material Requirements, Quantities & Submittals, Materials & Finishes, and Fonts & Symbols.

Contact:
 Environmental Graphics/Wayfinding
 AECOM
 407-843-6552
 150 N Orange Avenue, Suite 200
 Orlando, Florida 32801

Project Team:
 JMM
 SPC
 DMH

Drawn By: SPC

MATERIALS

- Custom 6" finial painted Matthews Paint MP00056 (Green Herb)
- 0.375" Aluminum Panel painted with Matthews Paint MP11490 (Vanadium Grey) with routed cutouts
 - Marine Life Center
 - Ferry Terminal
 - Visitors Info Center
 - Downtown
 - Shopping
 - Dining
- 0.25" Detachable Aluminum Blade painted with Matthews Paint MP00056 (Green Herb) with Avery HV 1200-101-R Opaque Retro-Reflective White
- 4" OD Pole painted with Matthews Paint MP11490 (Vanadium Grey)
- 6" OD Pole painted with Matthews Paint MP00056 (Green Herb)

Foundation per Code
Transpo Break-Safe Model AP
(See pages 36-38)

ASSEMBLY

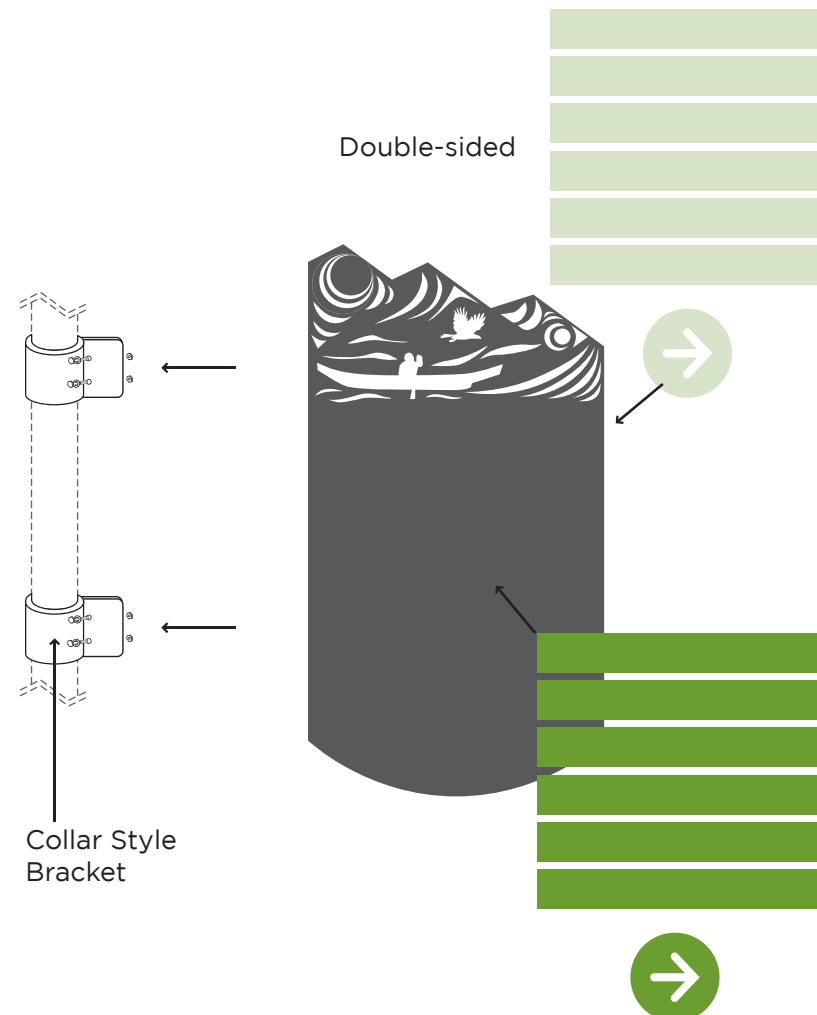

NOTE: Attach gray back panel to two custom collar style brackets with tamper proof fasteners. Fasten blades *ON BOTH SIDES* of panel with VHB tape. Bracket dimensions for each sign need to be field verified by fabricator to fit poles as pole types vary by location. Signs are double-sided.

Wayfinding System - Sign Details

Sign Type C
10330217.01
City of Port Angeles, Washington

Scale: 1/2" = 1'

Note: Drawing scale shown on plans is accurate for full size plans only. AECOM is not responsible for scale discrepancies caused by reduced size plans.

Description:
Pedestrian Directional

Original Issue Date: 2011.01.07

Revisions: 2011.02.08
2011.05.06

These drawings express visual design intent only. Final engineering, materials, and fabrication shall remain the responsibility of the fabricator.

The content of this document is subject to the design intent requirements outlined in the following sections: Fabricator Performance & Material Requirements, Quantities & Submittals, Materials & Finishes, and Fonts & Symbols.

Contact:
Environmental Graphics/Wayfinding
AECOM
407-843-6552
150 N Orange Avenue, Suite 200
Orlando, Florida 32801

Project Team:
JMM
SPC
DMH

Drawn By: SPC

Wayfinding System - Sign Details

Sign Type C
10330217.01
City of Port Angeles, Washington

Scale: NTS

Note: Drawing scale shown on plans is accurate for full size plans only. AECOM is not responsible for scale discrepancies caused by reduced size plans.

Description:
Pedestrian Directional

Original Issue Date: 2011.01.07

Revisions: 2011.02.08

These drawings express visual design intent only. Final engineering, materials, and fabrication shall remain the responsibility of the fabricator.

The content of this document is subject to the design intent requirements outlined in the following sections: Fabricator Performance & Material Requirements, Quantities & Submittals, Materials & Finishes, and Fonts & Symbols.

Contact:
Environmental Graphics/Wayfinding
AECOM
407-843-6552
150 N Orange Avenue, Suite 200
Orlando, Florida 32801

Project Team:
JMM
SPC
DH

Drawn By: Suchada Cartolano

NOTE: Digital artwork will be supplied by Client.
Do not recreate artwork.

FONT: Futura Standard Medium

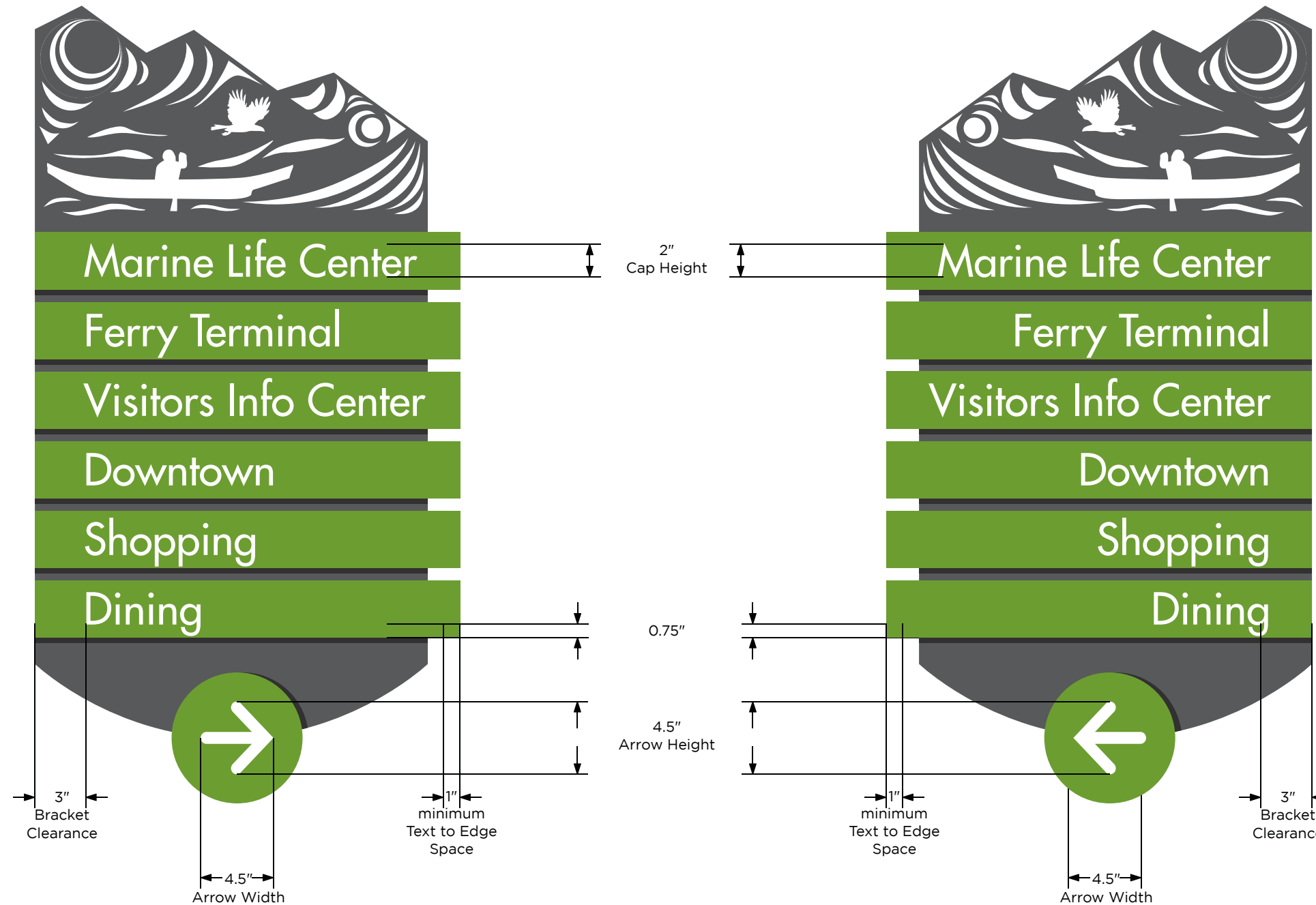

Wayfinding System - Sign Details

Sign Type D
10330217.01
City of Port Angeles, Washington

Scale: 1/2" = 1'

Note: Drawing scale shown on plans is accurate for full size plans only. AECOM is not responsible for scale discrepancies caused by reduced size plans.

Description:
Parking ID & ID with Kiosk

Original Issue Date: 2011.01.07

Revisions: 2011.01.25
2011.02.25
2011.05.27

These drawings express visual design intent only. Final engineering, materials, and fabrication shall remain the responsibility of the fabricator.

The content of this document is subject to the design intent requirements outlined in the following sections: Fabricator Performance & Material Requirements, Quantities & Submittals, Materials & Finishes, and Fonts & Symbols.

Contact:
Environmental Graphics/Wayfinding
AECOM
407-843-6552
150 N Orange Avenue, Suite 200
Orlando, Florida 32801

Project Team:
JMM
SPC
DMH

Drawn By: SPC

Parking D-1

Parking D-2

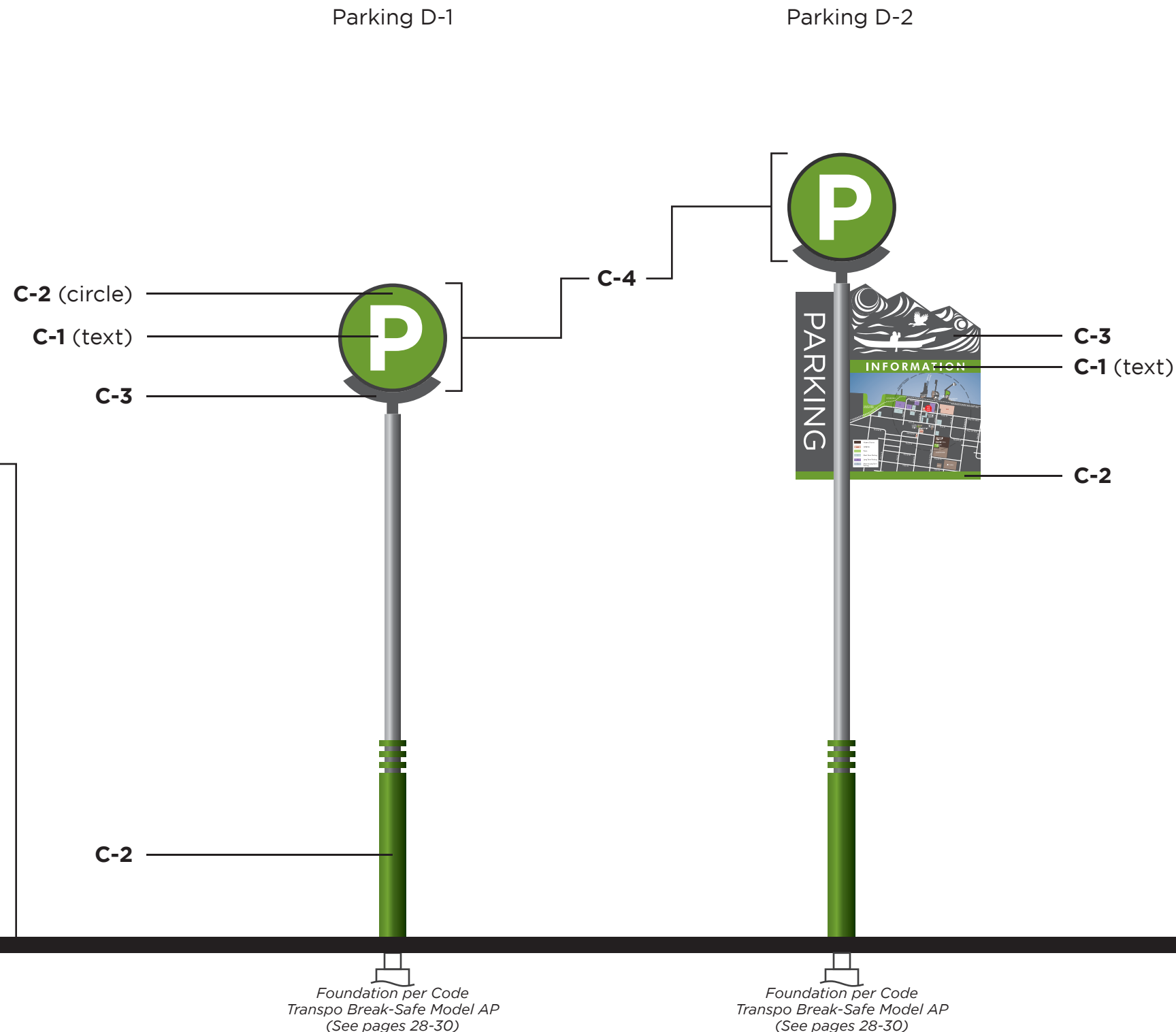

- C-1** White
Avery HV 1200-101-R Opaque
Retro-Reflective White
- C-2** Green
PMS 377C
MP00056 (Green Herb)
- C-3** Dark Gray
PMS 9C (Cool Gray)
MP11490 (Vanadium Grey)
- C-4** Matthews Anti-Graffiti
Clear Coat
**applied on all painted
surfaces*

DIMENSIONS

Perspective (NTS)

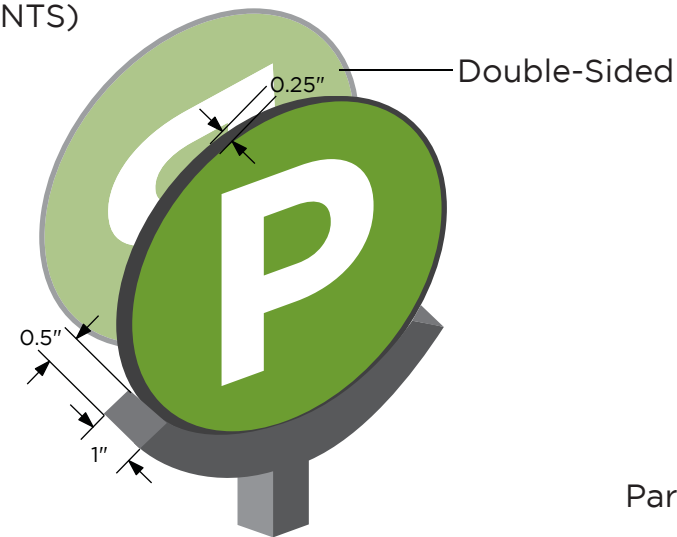

Parking D-1

Parking D-2

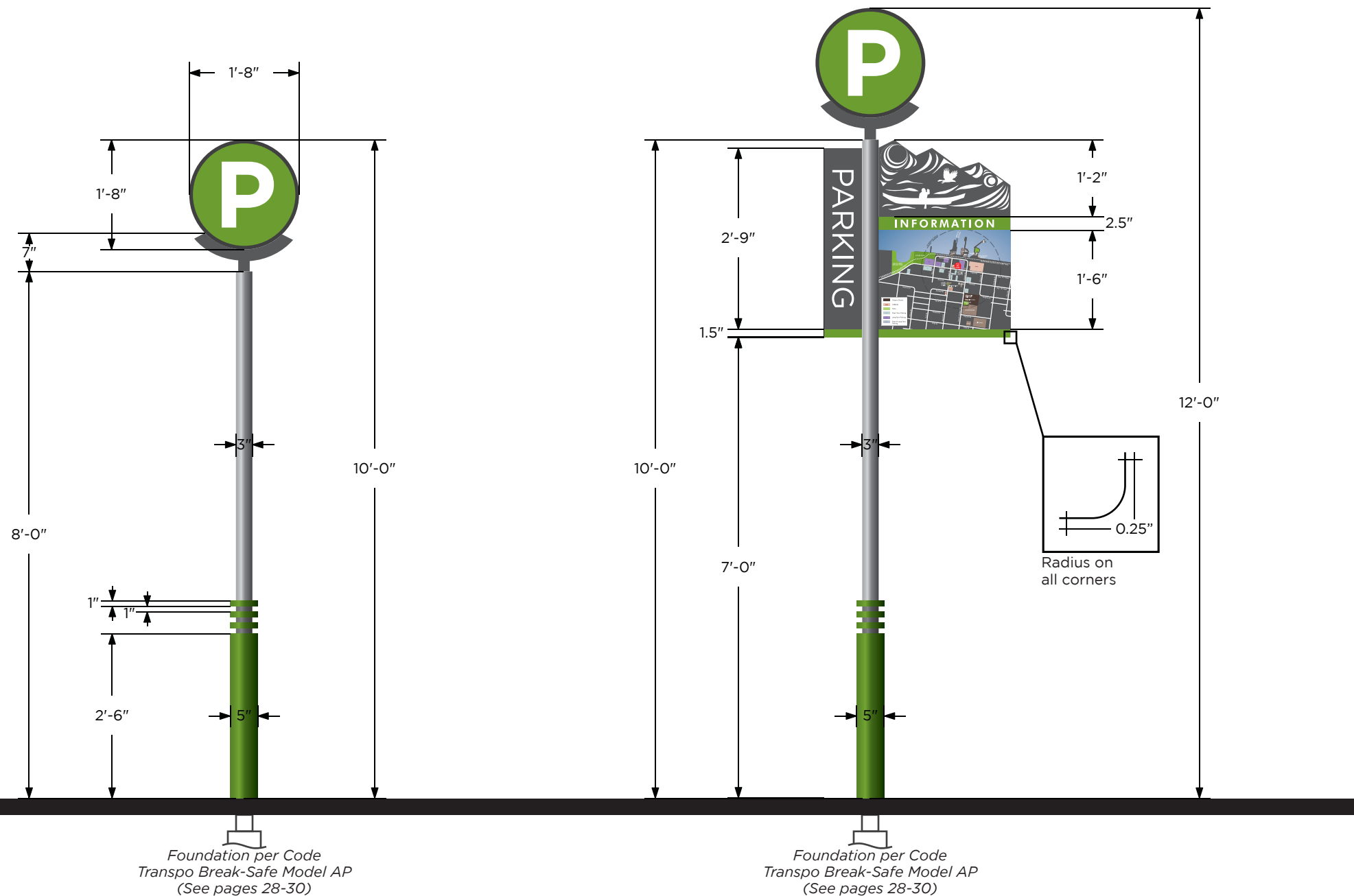

Scale: 1/2" = 1'

Note: Drawing scale shown on plans is accurate for full size plans only. AECOM is not responsible for scale discrepancies caused by reduced size plans.

Description:
Parking ID & ID with Kiosk

Original Issue Date: 2011.01.07

Revisions: 2011.01.25
2011.02.25
2011.05.27

These drawings express visual design intent only. Final engineering, materials, and fabrication shall remain the responsibility of the fabricator.

The content of this document is subject to the design intent requirements outlined in the following sections: Fabricator Performance & Material Requirements, Quantities & Submittals, Materials & Finishes, and Fonts & Symbols.

Contact:
Environmental Graphics/Wayfinding
AECOM
407-843-6552
150 N Orange Avenue, Suite 200
Orlando, Florida 32801

Project Team:
JMM
SPC
DMH

Drawn By: SPC

Wayfinding System - Sign Details

Sign Type D
10330217.01
City of Port Angeles, Washington

Scale: 1/2" = 1'

Note: Drawing scale shown on plans is accurate for full size plans only. AECOM is not responsible for scale discrepancies caused by reduced size plans.

Description:
Parking ID & ID with Kiosk

Original Issue Date: 2011.01.07

Revisions: 2011.01.25
2011.02.25
2011.05.27

These drawings express visual design intent only. Final engineering, materials, and fabrication shall remain the responsibility of the fabricator.

The content of this document is subject to the design intent requirements outlined in the following sections: Fabricator Performance & Material Requirements, Quantities & Submittals, Materials & Finishes, and Fonts & Symbols.

Contact:
Environmental Graphics/Wayfinding
AECOM
407-843-6552
150 N Orange Avenue, Suite 200
Orlando, Florida 32801

Project Team:
JMM
SPC
DMH

Drawn By: SPC

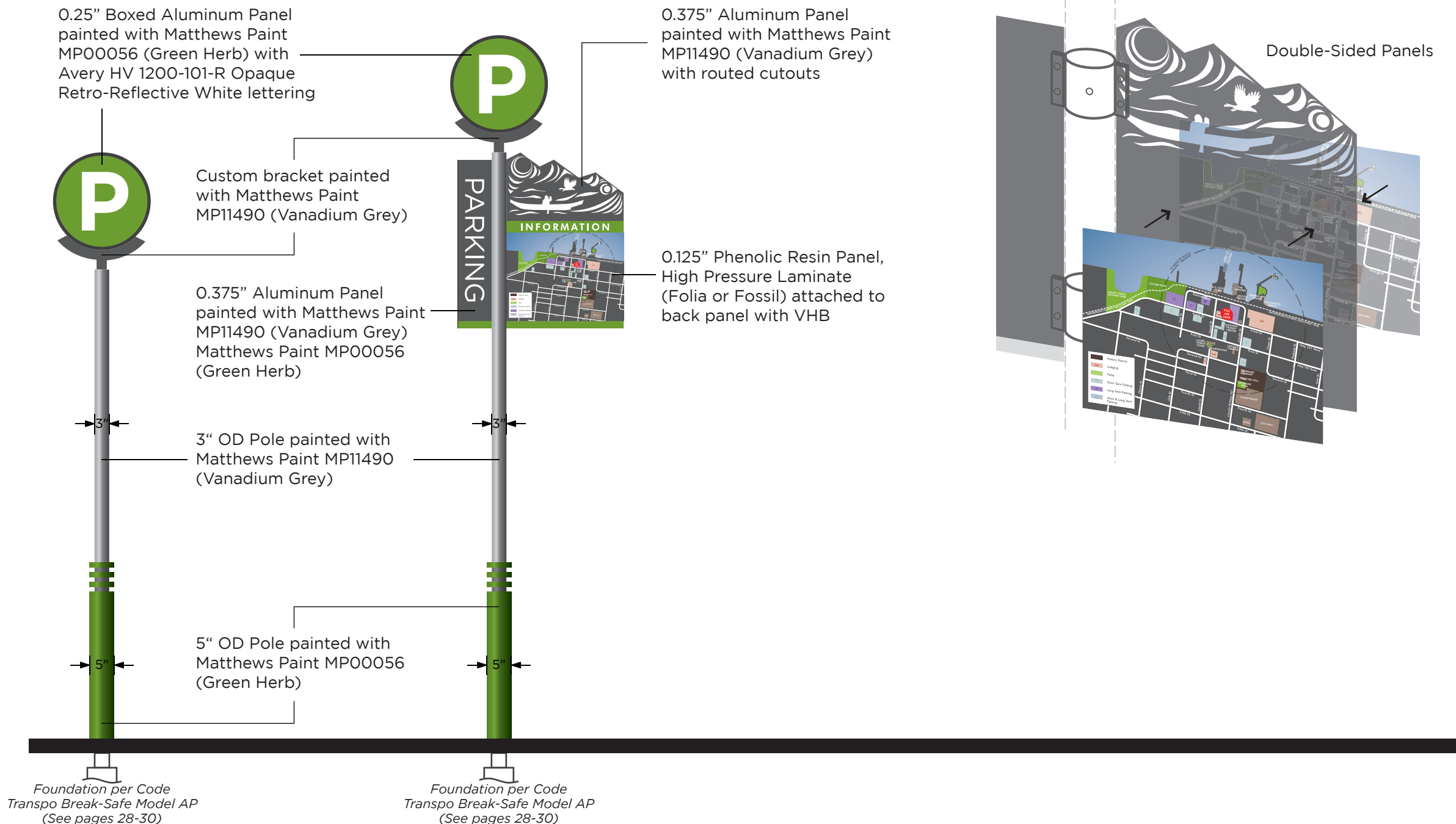

Wayfinding System - Sign Details

Sign Type D
10330217.01
City of Port Angeles, Washington

Scale: NTS

Note: Drawing scale shown on plans is accurate for full size plans only. AECOM is not responsible for scale discrepancies caused by reduced size plans.

Description:
Parking ID & ID with Kiosk

Original Issue Date: 2011.01.07

Revisions: 2011.01.25
2011.02.25
2011.05.27

These drawings express visual design intent only. Final engineering, materials, and fabrication shall remain the responsibility of the fabricator.

The content of this document is subject to the design intent requirements outlined in the following sections: Fabricator Performance & Material Requirements, Quantities & Submittals, Materials & Finishes, and Fonts & Symbols.

Contact:
Environmental Graphics/Wayfinding
AECOM
407-843-6552
150 N Orange Avenue, Suite 200
Orlando, Florida 32801

Project Team:
JMM
SPC
DMH

Drawn By: SPC

NOTE: Digital artwork will be supplied by Client.
Do not recreate artwork.

FONT: Gotham Bold

Parking D-1

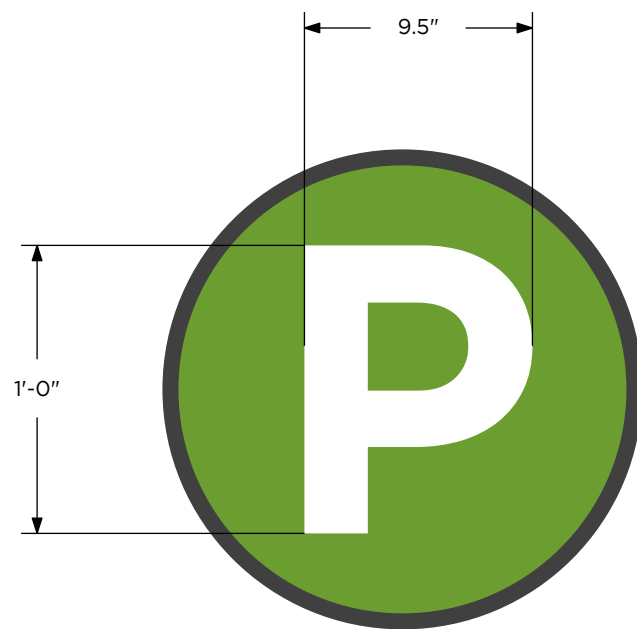

Parking D-2

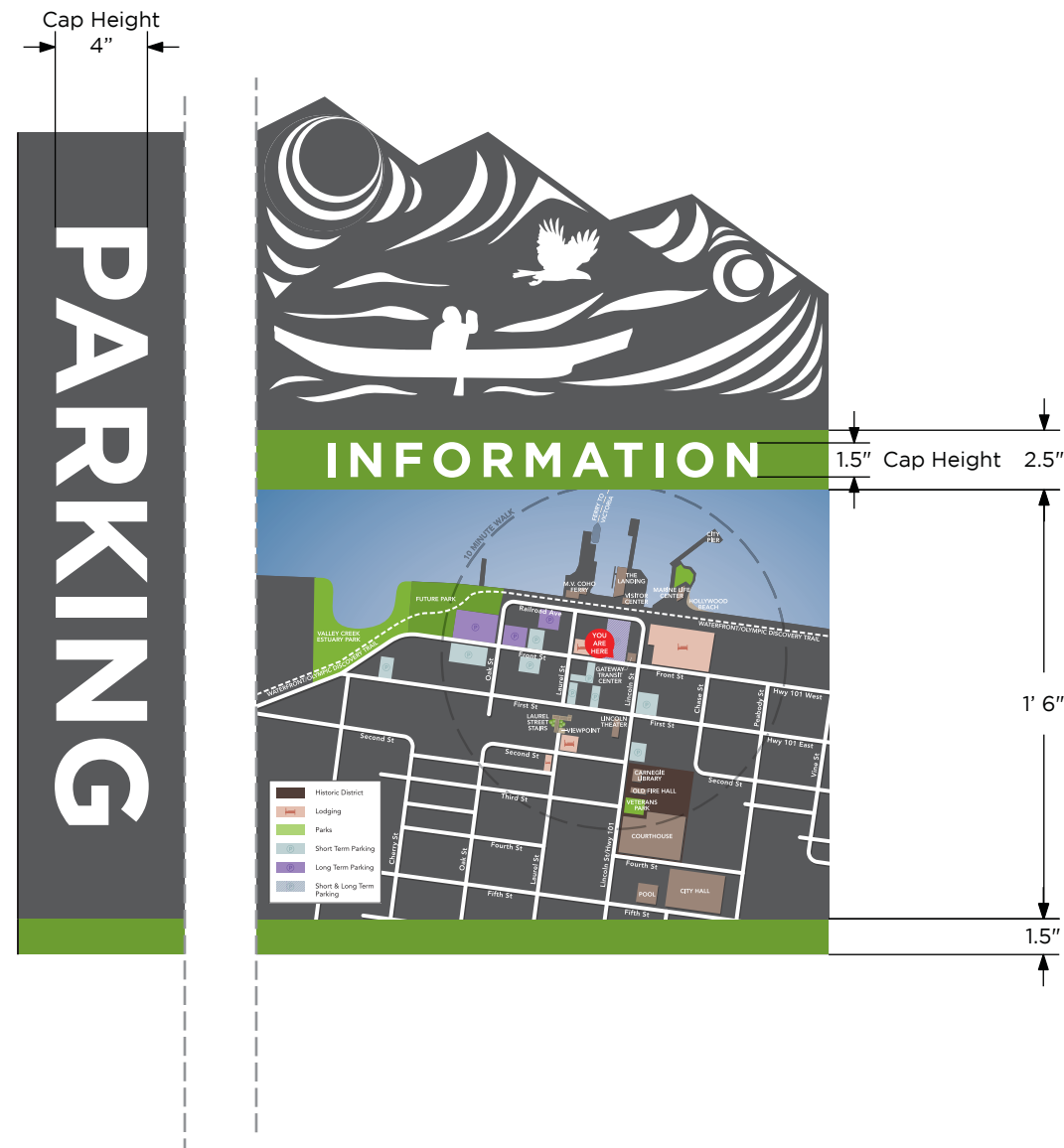

Wayfinding System - Sign Details

Sign Type E
10330217.01
City of Port Angeles, Washington

Scale: 1/2" = 1'

Note: Drawing scale shown on plans is accurate for full size plans only. AECOM is not responsible for scale discrepancies caused by reduced size plans.

Description:
Pedestrian Kiosk

Original Issue Date: 2011.01.07

Revisions: 2011.01.25 2011.05.06
 2011.02.25
 2011.03.01

These drawings express visual design intent only. Final engineering, materials, and fabrication shall remain the responsibility of the fabricator.

The content of this document is subject to the design intent requirements outlined in the following sections: Fabricator Performance & Material Requirements, Quantities & Submittals, Materials & Finishes, and Fonts & Symbols.

Contact:
Environmental Graphics/Wayfinding
AECOM
407-843-6552
150 N Orange Avenue, Suite 200
Orlando, Florida 32801

Project Team:
JMM
SPC
DMH

Drawn By: SPC

Front View

Back View

C-1	White Avery HV 1200-101-R Opaque Retro-Reflective White
C-2	Green PMS 377C MP00056 (Green Herb)
C-3	Dark Gray PMS 9C (Cool Gray) MP11490 (Vanadium Grey)

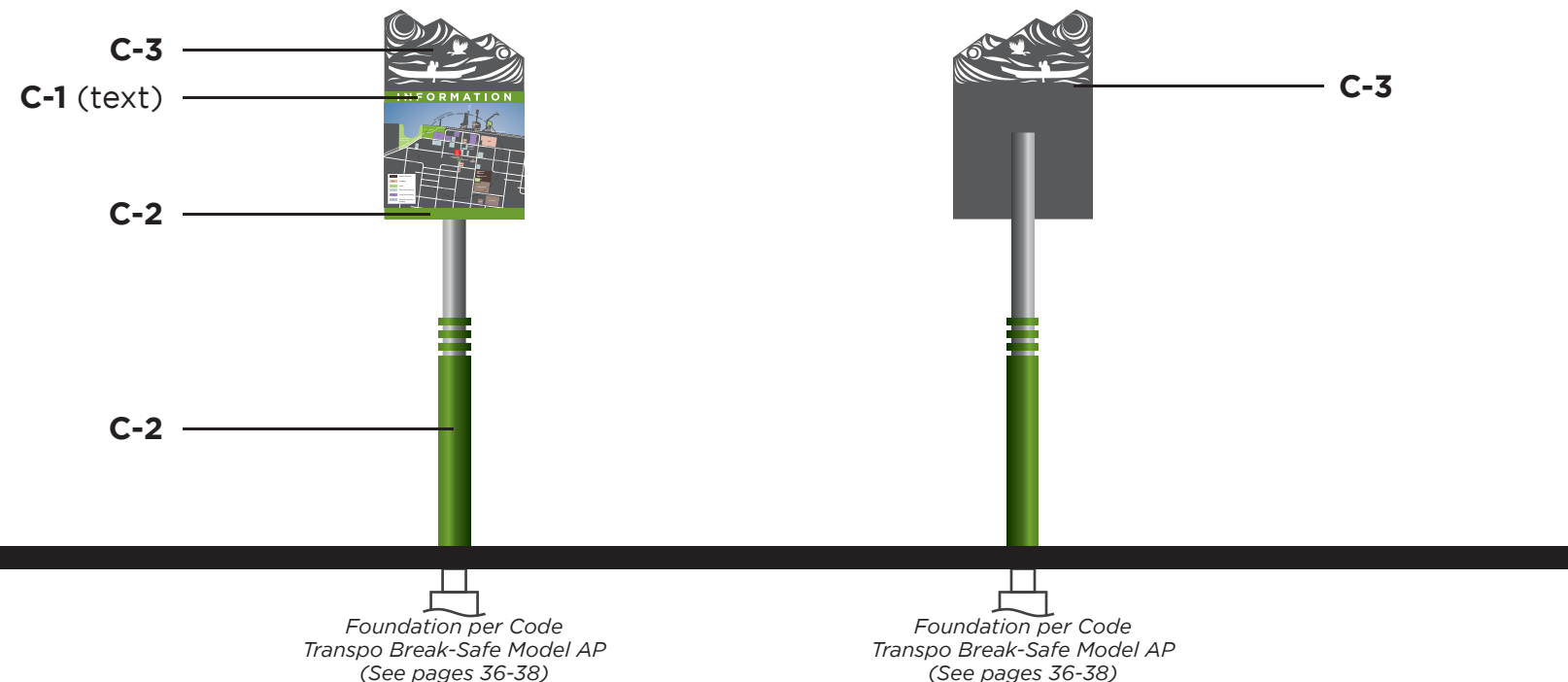

DIMENSIONS

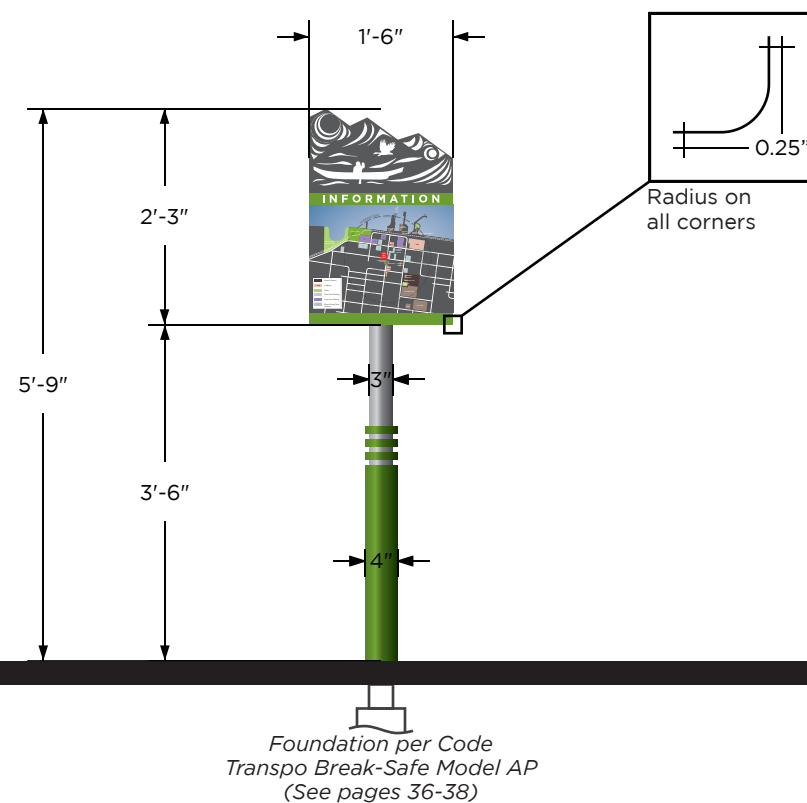

Wayfinding System - Sign Details

Sign Type E
10330217.01
City of Port Angeles, Washington

Scale: 1/2" = 1'

Note: Drawing scale shown on plans is accurate for full size plans only. AECOM is not responsible for scale discrepancies caused by reduced size plans.

Description:
Pedestrian Kiosk

Original Issue Date: 2011.01.07

Revisions: 2011.01.25 2011.05.06
2011.02.25
2011.03.01

These drawings express visual design intent only. Final engineering, materials, and fabrication shall remain the responsibility of the fabricator.

The content of this document is subject to the design intent requirements outlined in the following sections: Fabricator Performance & Material Requirements, Quantities & Submittals, Materials & Finishes, and Fonts & Symbols.

Contact:
Environmental Graphics/Wayfinding
AECOM
407-843-6552
150 N Orange Avenue, Suite 200
Orlando, Florida 32801

Project Team:
JMM
SPC
DMH

Drawn By: SPC

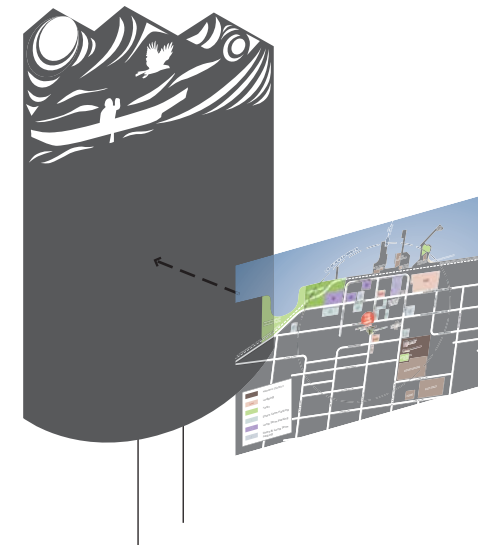
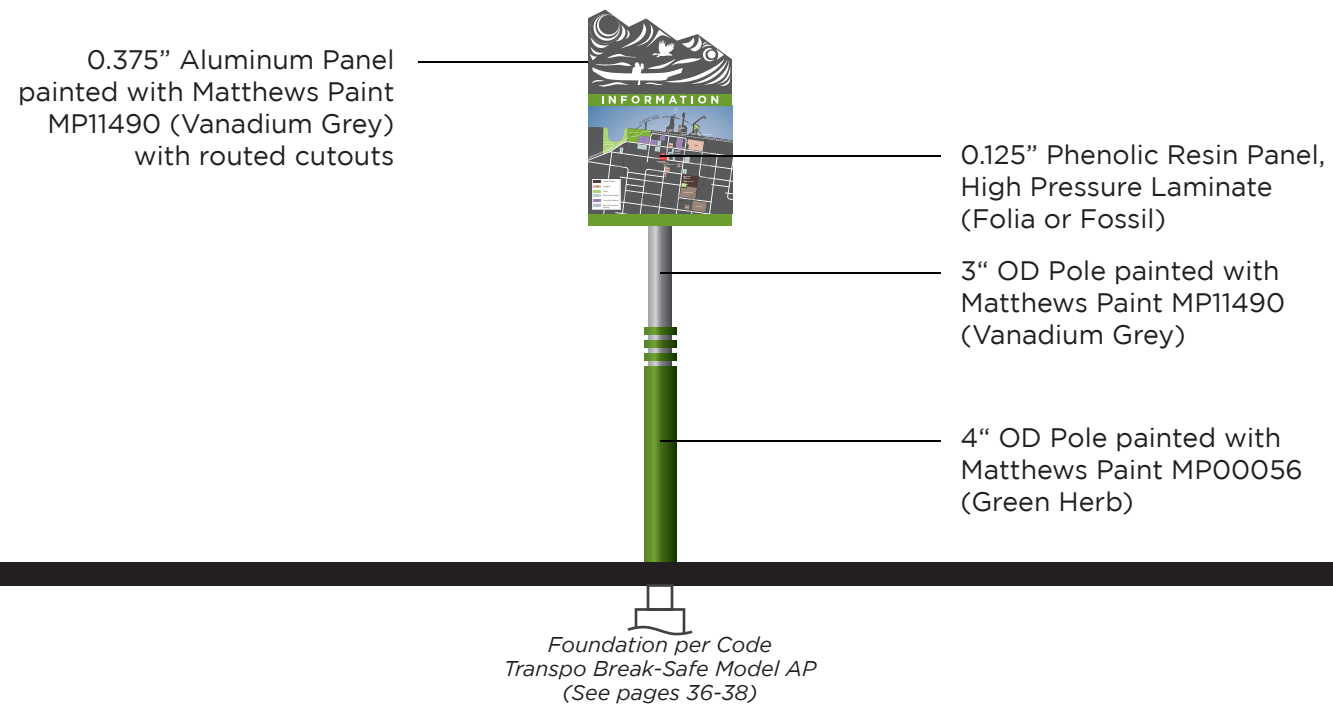
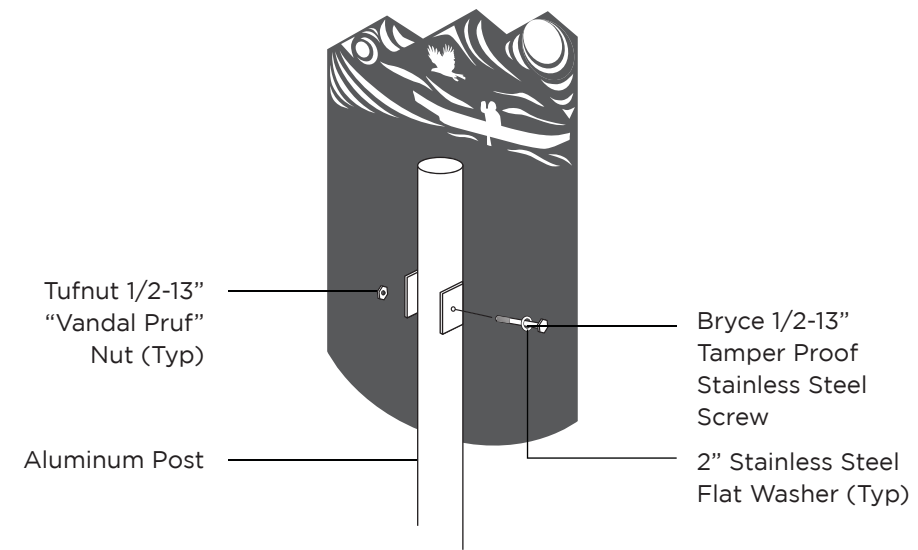

Wayfinding System - Sign Details

Sign Type E
10330217.01
City of Port Angeles, Washington

Scale: 1/2" = 1'

Note: Drawing scale shown on plans is accurate for full size plans only. AECOM is not responsible for scale discrepancies caused by reduced size plans.

Description:
Pedestrian Kiosk

Original Issue Date: 2011.01.07

Revisions: 2011.01.25 2011.05.06
2011.02.25
2011.03.01

These drawings express visual design intent only. Final engineering, materials, and fabrication shall remain the responsibility of the fabricator.

The content of this document is subject to the design intent requirements outlined in the following sections: Fabricator Performance & Material Requirements, Quantities & Submittals, Materials & Finishes, and Fonts & Symbols.

Contact:
Environmental Graphics/Wayfinding
AECOM
407-843-6552
150 N Orange Avenue, Suite 200
Orlando, Florida 32801

Project Team:
JMM
SPC
DMH

Drawn By: SPC

Wayfinding System - Sign Details

Sign Type E
10330217.01
City of Port Angeles, Washington

Scale: NTS
Note: Drawing scale shown on plans is accurate for full size plans only. AECOM is not responsible for scale discrepancies caused by reduced size plans.

Description:
Pedestrian Kiosk

Original Issue Date: 2011.01.07

Revisions: 2011.01.25 2011.05.06
2011.02.25
2011.03.01

These drawings express visual design intent only. Final engineering, materials, and fabrication shall remain the responsibility of the fabricator.

The content of this document is subject to the design intent requirements outlined in the following sections: Fabricator Performance & Material Requirements, Quantities & Submittals, Materials & Finishes, and Fonts & Symbols.

Contact:
Environmental Graphics/Wayfinding
AECOM
407-843-6552
150 N Orange Avenue, Suite 200
Orlando, Florida 32801

Project Team:
JMM
SPC
DH

Drawn By: SPC

NOTE: Digital artwork will be supplied by Client.
Do not recreate artwork.

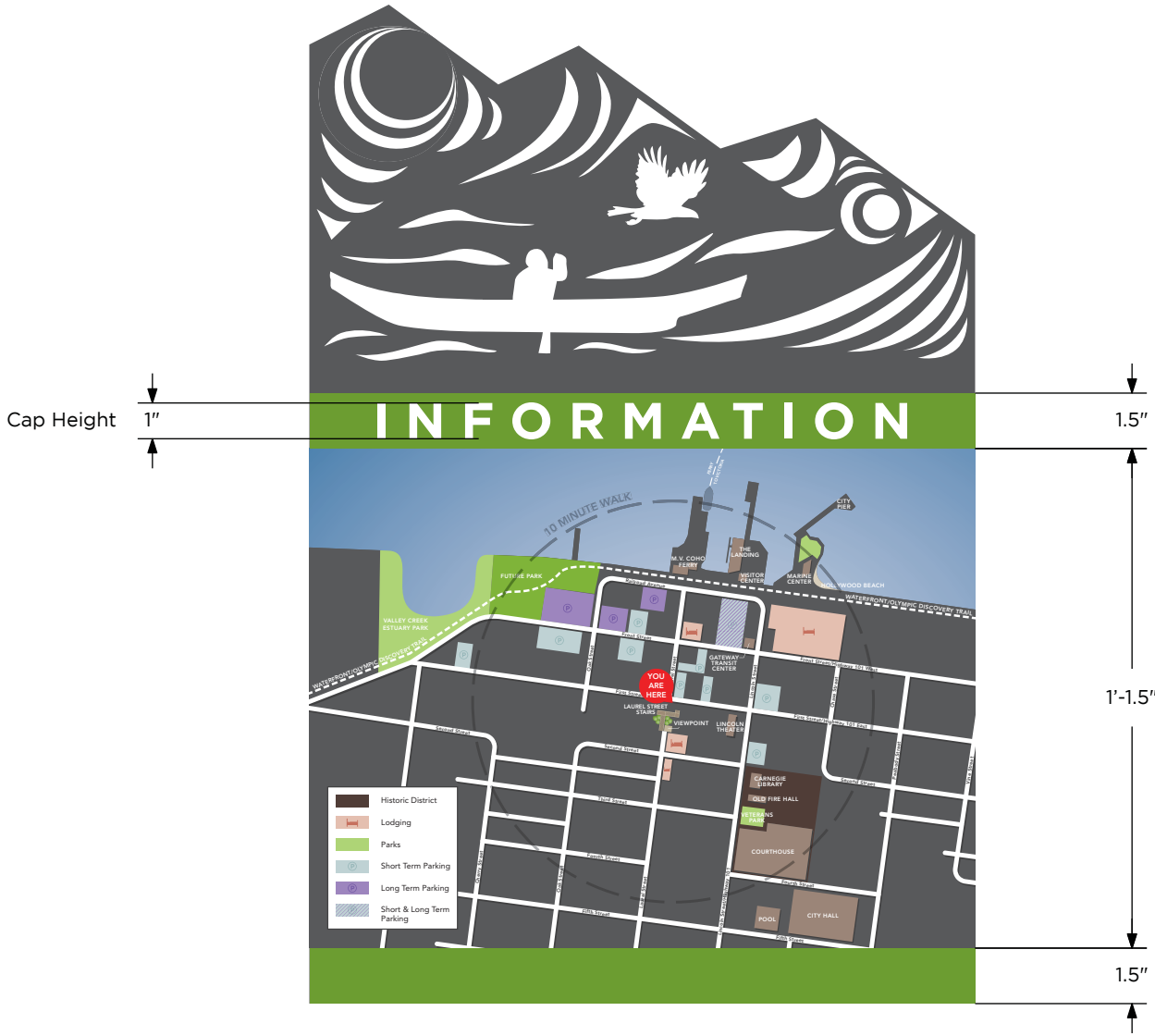

Wayfinding System - Sign Details

Sign Type F
10330217.01
City of Port Angeles, Washington

Scale: 1/2" = 1'

Note: Drawing scale shown on plans is accurate for full size plans only. AECOM is not responsible for scale discrepancies caused by reduced size plans.

Description:
Historic District

Original Issue Date: 2011.05.06

Revisions:

These drawings express visual design intent only. Final engineering, materials, and fabrication shall remain the responsibility of the fabricator.

The content of this document is subject to the design intent requirements outlined in the following sections: Fabricator Performance & Material Requirements, Quantities & Submittals, Materials & Finishes, and Fonts & Symbols.

Contact:
Environmental Graphics/Wayfinding
AECOM
407-843-6552
150 N Orange Avenue, Suite 200
Orlando, Florida 32801

Project Team:
JMM
SPC
DMH

Drawn By: SPC

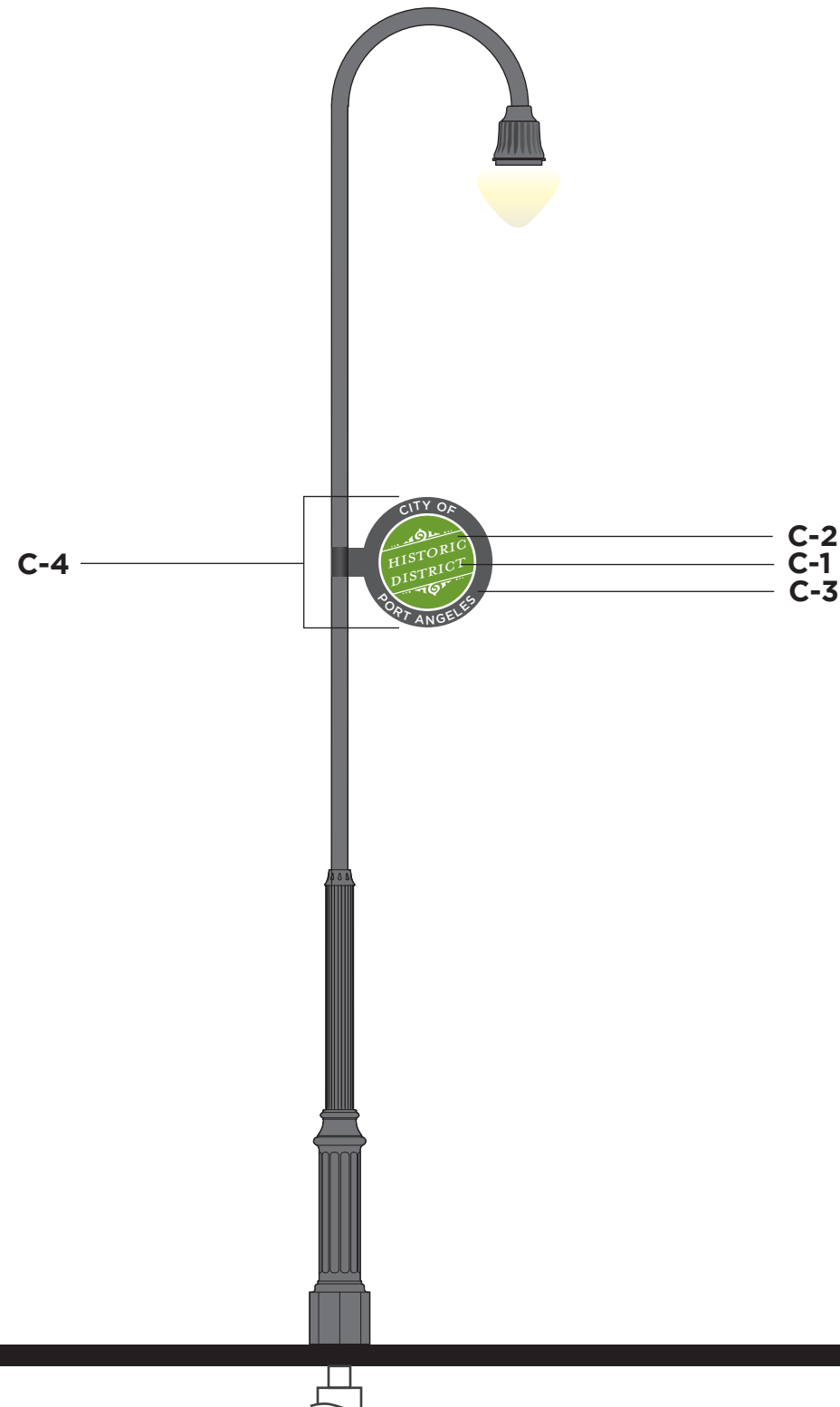

Foundation per Code
Transpo Break-Safe Model AP
(See pages 36-38)

- C-1** White
Avery HV 1200-101-R Opaque
Retro-Reflective White
- C-2** Green
PMS 377C
MP00056 (Green Herb)
- C-3** Dark Gray
PMS 9C (Cool Gray)
MP11490 (Vanadium Grey)
- C-4** Matthews Anti-Graffiti
Clear Coat
**applied on all painted
surfaces*

DIMENSIONS



Wayfinding System - Sign Details

Sign Type F
10330217.01
City of Port Angeles, Washington

Scale: 1/2" = 1'

Note: Drawing scale shown on plans is accurate for full size plans only. AECOM is not responsible for scale discrepancies caused by reduced size plans.

Description:
Historic District

Original Issue Date: 2011.05.06

Revisions:

These drawings express visual design intent only. Final engineering, materials, and fabrication shall remain the responsibility of the fabricator.

The content of this document is subject to the design intent requirements outlined in the following sections: Fabricator Performance & Material Requirements, Quantities & Submittals, Materials & Finishes, and Fonts & Symbols.

Contact:
Environmental Graphics/Wayfinding
AECOM
407-843-6552
150 N Orange Avenue, Suite 200
Orlando, Florida 32801

Project Team:
JMM
SPC
DMH

Drawn By: SPC

MATERIALS

ASSEMBLY

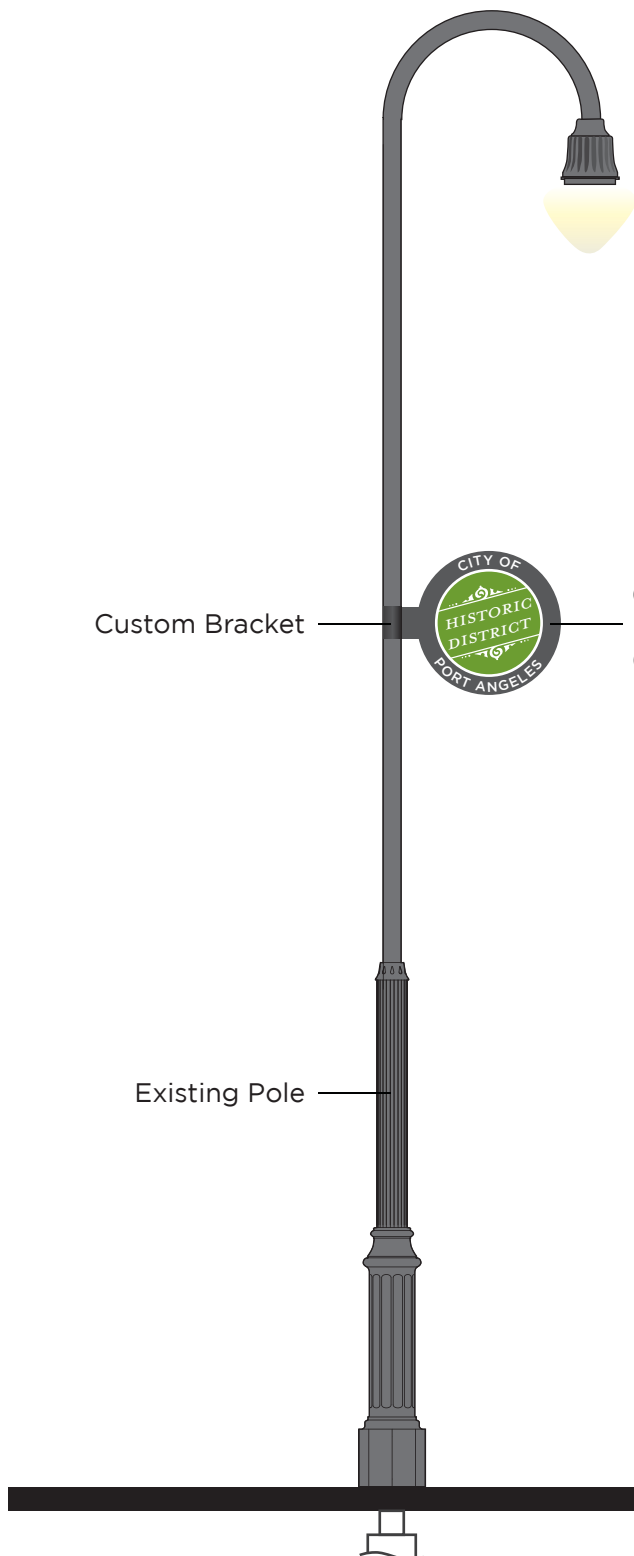

Custom Bracket

0.125" Phenolic Resin Panel, High Pressure Laminate (Folia or Fossil)

Existing Pole

Foundation per Code
Transpo Break-Safe Model AP
(See pages 36-38)

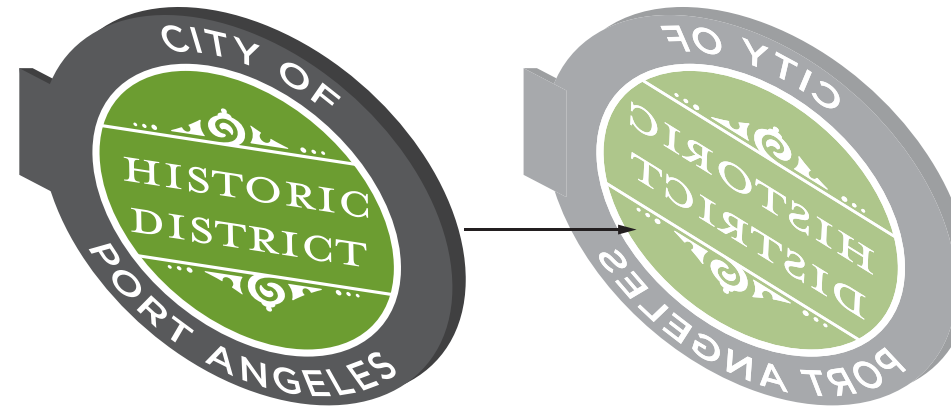

Attach 2 Phenolic Resin Panels with VHB to make Double-Sided Sign

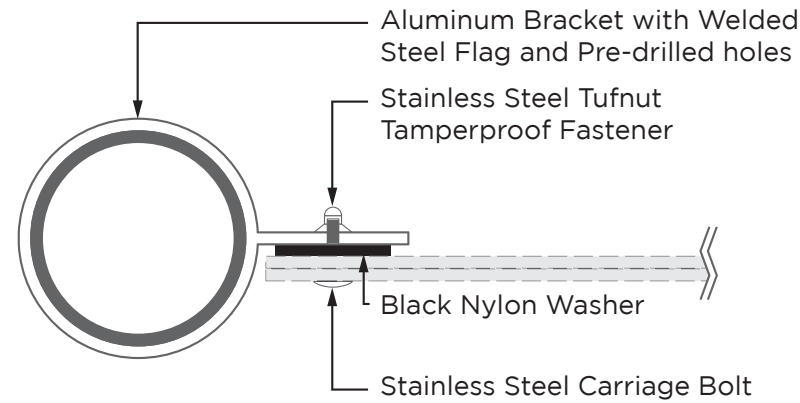

Aluminum Bracket with Welded Steel Flag and Pre-drilled holes

Stainless Steel Tufnut Tamperproof Fastener

Black Nylon Washer

Stainless Steel Carriage Bolt



Scale: 1/2" = 1'

Note: Drawing scale shown on plans is accurate for full size plans only. AECOM is not responsible for scale discrepancies caused by reduced size plans.

Description:
Historic District

Original Issue Date: 2011.05.06

Revisions:

These drawings express visual design intent only. Final engineering, materials, and fabrication shall remain the responsibility of the fabricator.

The content of this document is subject to the design intent requirements outlined in the following sections: Fabricator Performance & Material Requirements, Quantities & Submittals, Materials & Finishes, and Fonts & Symbols.

Contact:
Environmental Graphics/Wayfinding
AECOM
407-843-6552
150 N Orange Avenue, Suite 200
Orlando, Florida 32801

Project Team:
JMM
SPC
DMH

Drawn By: SPC

NOTE: Digital artwork will be supplied by Client.
Do not recreate artwork.



Wayfinding System - Sign Details

Sign Type F
10330217.01
City of Port Angeles, Washington

Scale: NTS

Note: Drawing scale shown on plans is accurate for full size plans only. AECOM is not responsible for scale discrepancies caused by reduced size plans.

Description:
Historic District

Original Issue Date: 2011.05.06

Revisions:

These drawings express visual design intent only. Final engineering, materials, and fabrication shall remain the responsibility of the fabricator.

The content of this document is subject to the design intent requirements outlined in the following sections: Fabricator Performance & Material Requirements, Quantities & Submittals, Materials & Finishes, and Fonts & Symbols.

Contact:
Environmental Graphics/Wayfinding
AECOM
407-843-6552
150 N Orange Avenue, Suite 200
Orlando, Florida 32801

Project Team:
JMM
SPC
DMH

Drawn By: SPC

Wayfinding System - Sign Details

Sign Type G
10330217.01
City of Port Angeles, Washington

Scale: 1/2" = 1'

Note: Drawing scale shown on plans is accurate for full size plans only. AECOM is not responsible for scale discrepancies caused by reduced size plans.

Description:
Tsunami Warning

Original Issue Date: 2011.04.01

Revisions: 2011.05.17
2011.06.13

These drawings express visual design intent only. Final engineering, materials, and fabrication shall remain the responsibility of the fabricator.

The content of this document is subject to the design intent requirements outlined in the following sections: Fabricator Performance & Material Requirements, Quantities & Submittals, Materials & Finishes, and Fonts & Symbols.

Contact:
Environmental Graphics/Wayfinding
AECOM
407-843-6552
150 N Orange Avenue, Suite 200
Orlando, Florida 32801

Project Team:
JMM
SPC
DMH

Drawn By: SPC

Tsunami Evacuation Route
G-1

Tsunami Evacuation Route
with Arrow
G-2



C-5
C-1

- C-1** White
Avery HV 1200-101-R Opaque
Retro-Reflective White
- C-2** Green
PMS 377C
MP00056 (Green Herb)
- C-3** Dark Gray
PMS 9C (Cool Gray)
MP11490 (Vanadium Grey)
- C-4** Matthews Anti-Graffiti
Clear Coat
**applied on all painted
surfaces*
- C-5** Blue
PMS 293C
MP02160 (Sailboat Blue)

Foundation per Code
Transpo Break-Safe Model AP
(See pages 36-38)

Foundation per Code
Transpo Break-Safe Model AP
(See pages 36-38)

Wayfinding System - Sign Details

Sign Type G
10330217.01
City of Port Angeles, Washington

Scale: 1/2" = 1'

Note: Drawing scale shown on plans is accurate for full size plans only. AECOM is not responsible for scale discrepancies caused by reduced size plans.

Description:
Tsunami Warning

Original Issue Date: 2011.04.01

Revisions: 2011.05.17
2011.06.13

These drawings express visual design intent only. Final engineering, materials, and fabrication shall remain the responsibility of the fabricator.

The content of this document is subject to the design intent requirements outlined in the following sections: Fabricator Performance & Material Requirements, Quantities & Submittals, Materials & Finishes, and Fonts & Symbols.

Contact:
Environmental Graphics/Wayfinding
AECOM
407-843-6552
150 N Orange Avenue, Suite 200
Orlando, Florida 32801

Project Team:
JMM
SPC
DMH

Drawn By: SPC

Tsunami G-1

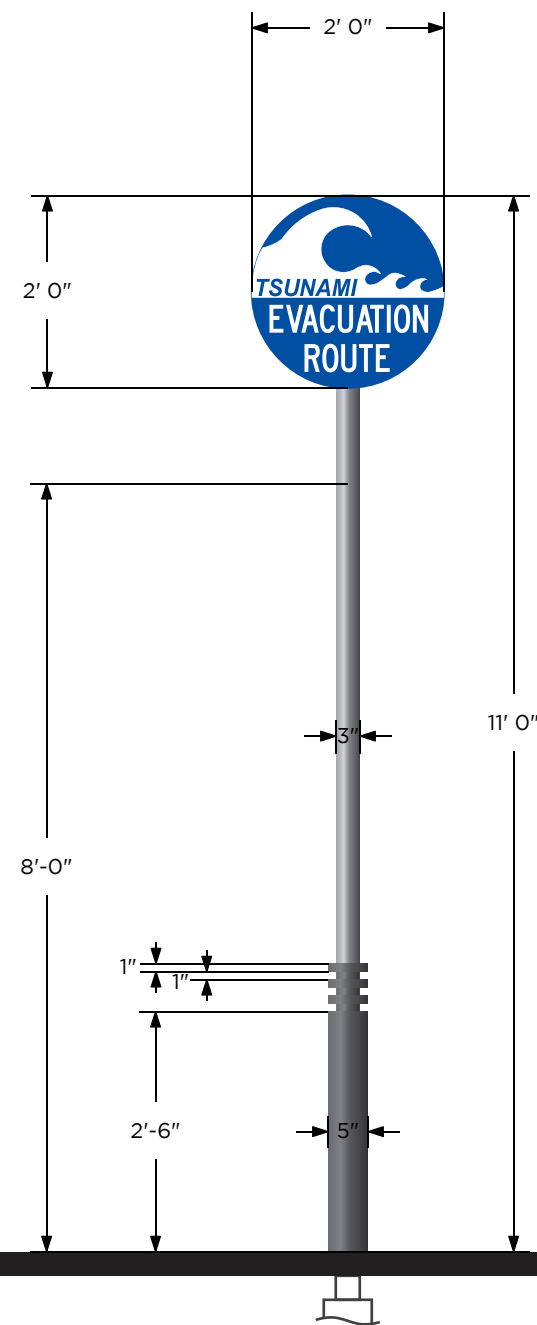

Foundation per Code
Transpo Break-Safe Model AP
(See pages 36-38)

Tsunami G-2

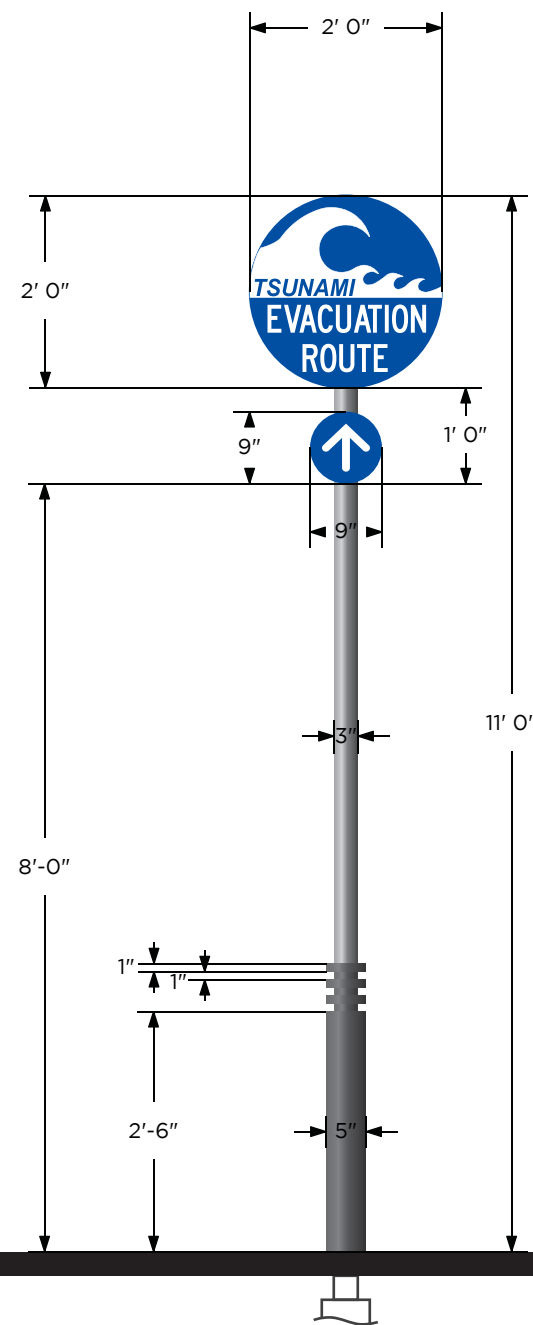

Foundation per Code
Transpo Break-Safe Model AP
(See pages 36-38)

<p>AECOM / Glatting Jackson</p>	
<p>Wayfinding System - Sign Details</p>	
<p>Sign Type G 10330217.01 City of Port Angeles, Washington</p>	
<p>Scale: 1/2" = 1'</p> <p><small>Note: Drawing scale shown on plans is accurate for full size plans only. AECOM is not responsible for scale discrepancies caused by reduced size plans.</small></p>	
<p>Description: Tsunami Warning</p>	
<p>Original Issue Date: 2011.04.01</p>	
<p>Revisions: 2011.05.17 2011.06.13</p>	
<p>These drawings express visual design intent only. Final engineering, materials, and fabrication shall remain the responsibility of the fabricator.</p> <p>The content of this document is subject to the design intent requirements outlined in the following sections: Fabricator Performance & Material Requirements, Quantities & Submittals, Materials & Finishes, and Fonts & Symbols.</p>	
<p>Contact: Environmental Graphics/Wayfinding AECOM 407-843-6552 150 N Orange Avenue, Suite 200 Orlando, Florida 32801</p>	
<p>Project Team: JMM SPC DMH</p>	
<p>Drawn By: SPC</p>	

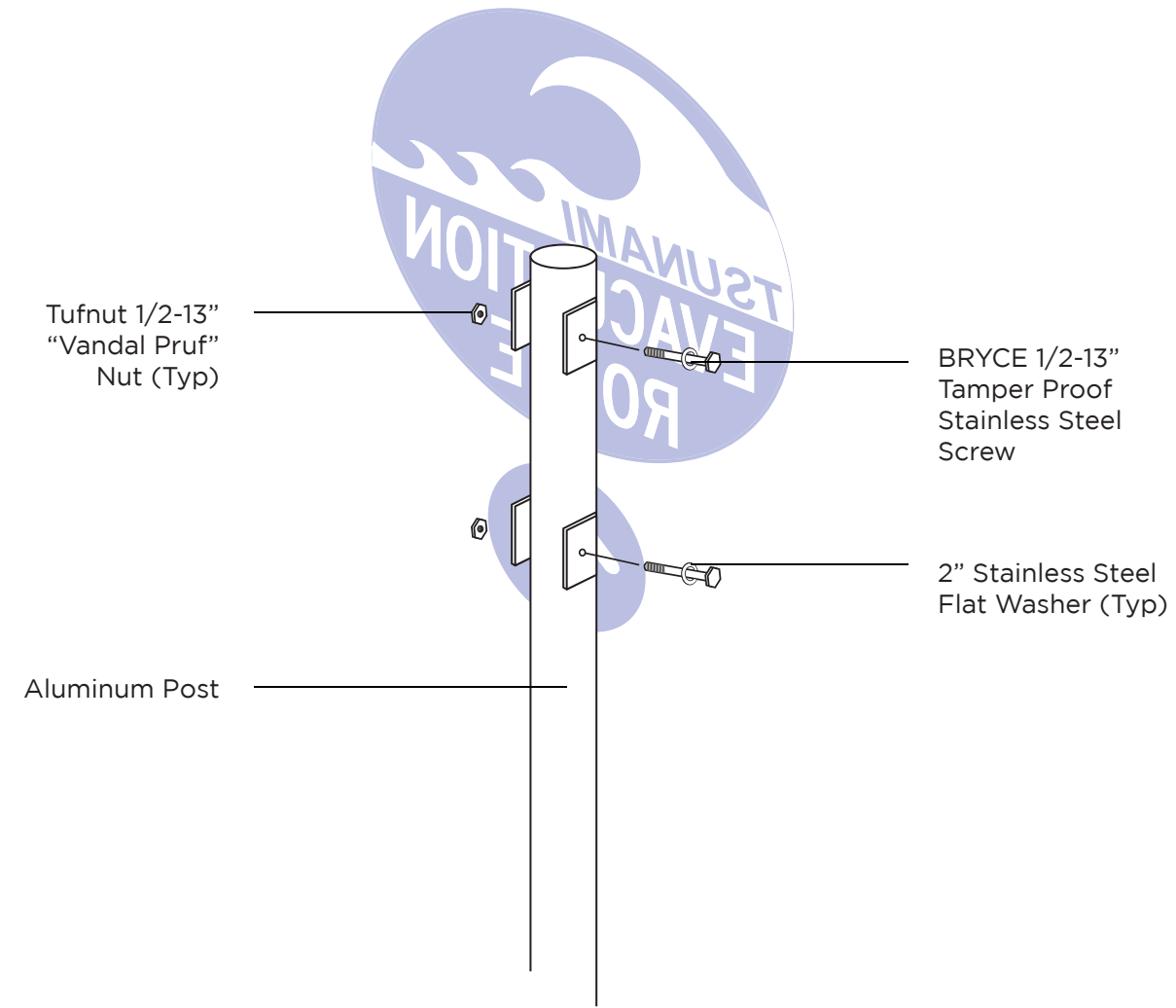
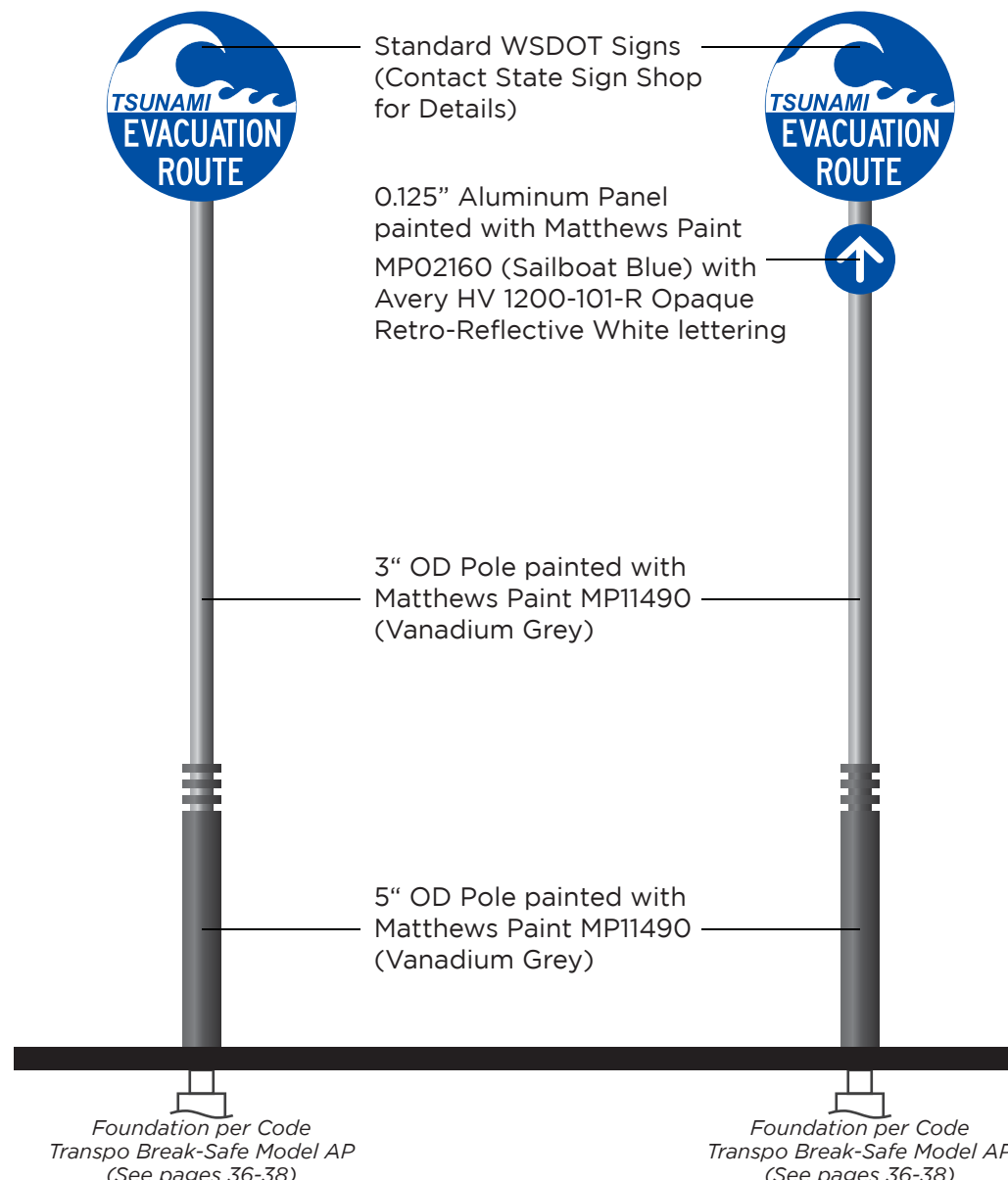

NOTE: Digital artwork will be supplied by Client.
Do not recreate artwork.

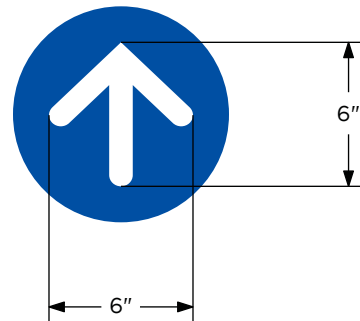

Wayfinding System - Sign Details

Sign Type G
10330217.01
City of Port Angeles, Washington

Scale: NTS

Note: Drawing scale shown on plans is accurate for full size plans only. AECOM is not responsible for scale discrepancies caused by reduced size plans.

Description:
Tsunami Warning

Original Issue Date: 2011.04.01

Revisions: 2011.05.17
2011.06.13

These drawings express visual design intent only. Final engineering, materials, and fabrication shall remain the responsibility of the fabricator.

The content of this document is subject to the design intent requirements outlined in the following sections: Fabricator Performance & Material Requirements, Quantities & Submittals, Materials & Finishes, and Fonts & Symbols.

Contact:
Environmental Graphics/Wayfinding
AECOM
407-843-6552
150 N Orange Avenue, Suite 200
Orlando, Florida 32801

Project Team:
JMM
SPC
DMH

Drawn By: SPC

FOUNDATION PER CODE — TRANSPO BREAK-SAFE MODEL AP

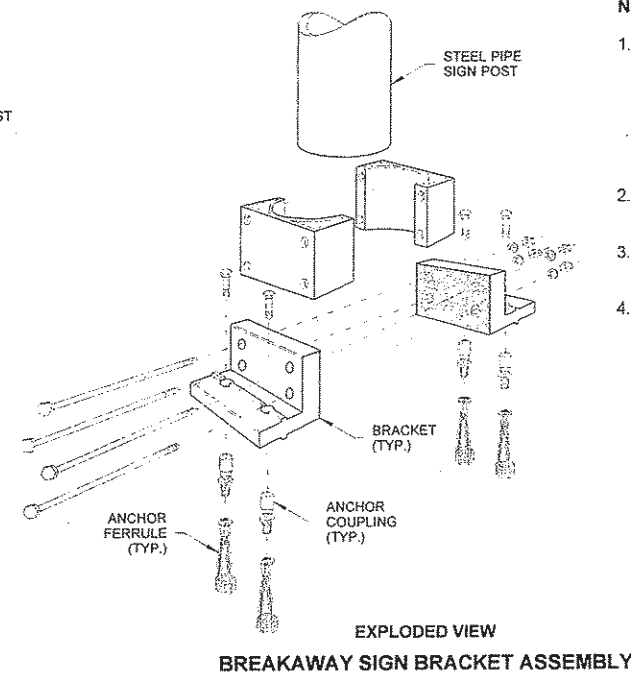
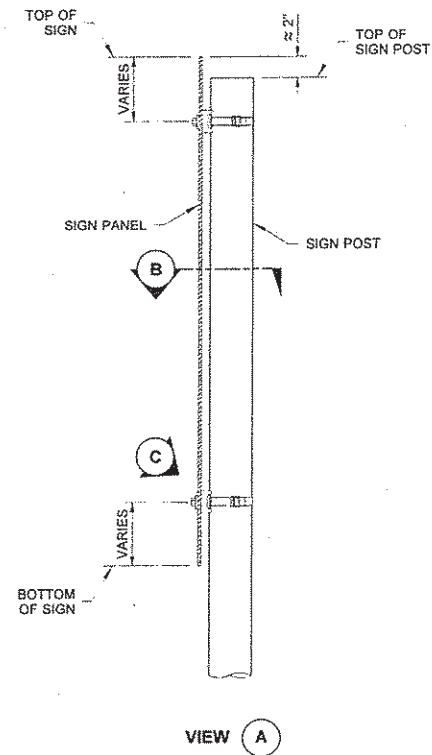
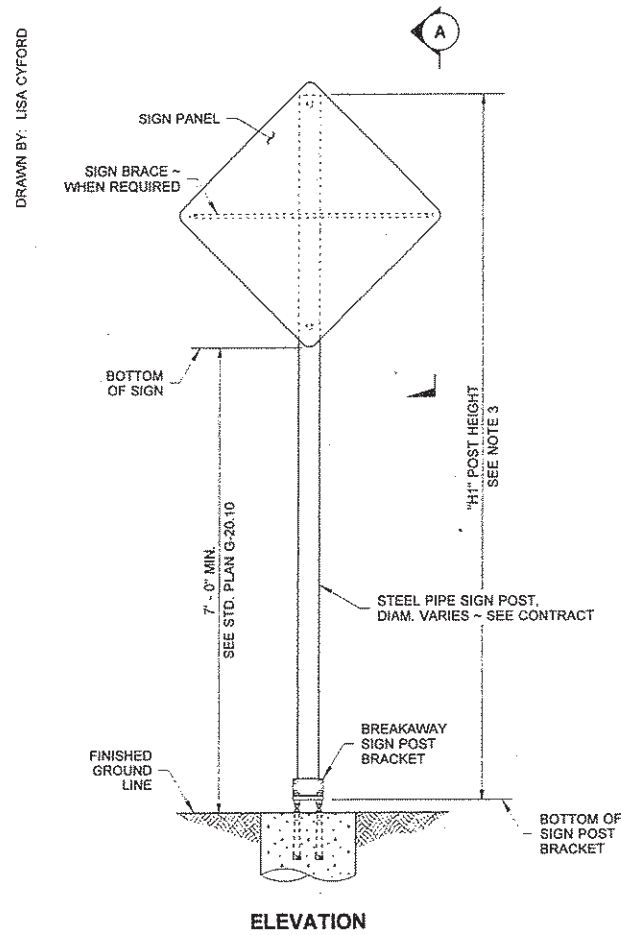

NOTES

1. Dimensions for the parts used to assemble the base connections are intentionally not shown. Base connections are patented, manufactured products that are in compliance with NCHRP 350 crash test criteria. The base connection details are only shown on this plan to illustrate how the parts are assembled.
2. For Steel Sign Support Foundation, see Standard Plan G-25.10.
3. For "H1" refer to the Sign Specification Sheet in the Contract.
4. Mounting brackets with steel straps shall be the stainless steel one bolt, flared leg bracket and 3/4" wide, 0.030" thick strap "Band-it" products or an approved equal.

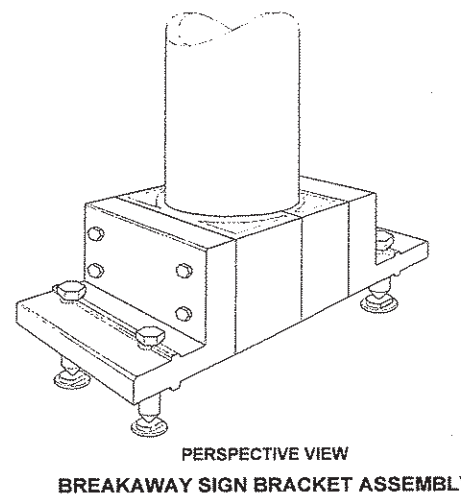
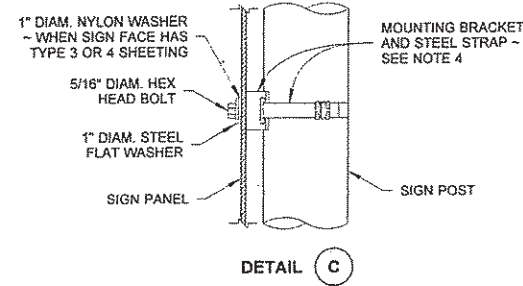
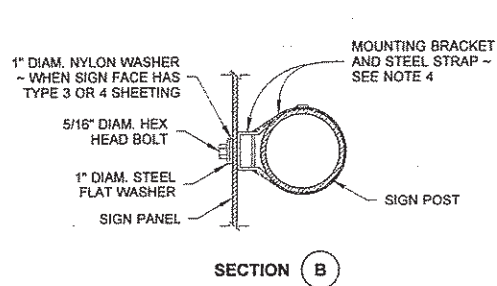

**STEEL SIGN SUPPORT
TYPE AP
INSTALLATION DETAILS
STANDARD PLAN G-24.10-00**
SHEET 1 OF 1 SHEET

APPROVED FOR PUBLICATION
Paula B. [Signature] 11/3/07
STATE DESIGN ENGINEER DATE
Washington State Department of Transportation

Note: Drawing scale shown on plans is accurate for full size plans only. AECOM is not responsible for scale discrepancies caused by reduced size plans.

Description:
Transpo Base Specifications

Original Issue Date: 2011.05.04

Revisions:

These drawings express visual design intent only. Final engineering, materials, and fabrication shall remain the responsibility of the fabricator.

The content of this document is subject to the design intent requirements outlined in the following sections: Fabricator Performance & Material Requirements, Quantities & Submittals, Materials & Finishes, and Fonts & Symbols.

Contact:
Environmental Graphics/Wayfinding
AECOM
407-843-6552
150 N Orange Avenue, Suite 200
Orlando, Florida 32801

Project Team:
JMM
SPC
DH

Drawn By: SPC

PARTS LIST

ITEM	DESCRIPTION	SIZE/SPECIFICATIONS	QTY/ POST	PART NUMBER
1	Bracket, Type AP3, AP3.5, AP4, AP4.5	6061-T6 Aluminum	2	SBAK6172, 6173, 6174
2	Bracket Adaptor, Type AP3, AP3.5, AP4, AP4.5	6061-T6 Aluminum	2	SBADP30, 35, 40, 45
3	Bracket Hardware Assembly, Type AP3, AP3.5, AP4, AP4.5, includes:		1	SB-AP3H, 3.5H, 4H, 4.5H
3a	Bolt	12.7mm(1/2")-13UNC, Hex Head, ASTM A325, Galv. ASTM A153	4	
3b	Lock Washer	12.7mm(1/2"), ANSI B18-21-1, Galv. ASTM A153	4	
3c	Nut	12.7mm(1/2")-13UNC, Heavy Hex, ASTM A563 Gr. DH, Galv. ASTM A153	4	
4	Coupling & Special Bolt Assembly, Type A, includes:		1	SB-CALP
4a	Special Bolt	15.9mm(5/8")-11UNC, ASTM A449, Galv. ASTM A153/B695	4	
4b	Coupling	15.9mm(5/8")-11UNC, LP, AMS 6378D, Galv. ASTM A153, Polyester Coat	4	
4c	Shim	15.9mm(5/8") Horseshoe, 14 Gauge, Galv. Steel Sheet	2	
4d	Shim	15.9mm(5/8") Horseshoe, 18 Gauge, Galv. Steel Sheet	2	
5	Anchor Assembly, Type A, includes:		1	SBAAPK
5a	Anchor	15.9mm(5/8")-11UNC, 304 S.S. Ferrule, AISI 1038 1045 Rod, AISI 1008 Coil	4	

BREAK-SAFE MODEL AP SELECTION TABLE

BREAK-SAFE MODEL	OUTSIDE PIPE DIAMETER (D)	NOMINAL PIPE SIZE
AP3	76 mm (3")	64 mm (2-1/2")
AP3.5	89 mm (3-1/2")	76 mm (3")
AP4	102 mm (4")	89 mm (3-1/2")
AP4.5	114 mm (4-1/2")	102 mm (4")

GENERAL NOTES:

- Break-Safe meets all requirements of "AASHTO Standard Specifications for Structural Supports for Highway Signs, Luminaires and Traffic Signals."
- Break-Safe Model AP is designed to fit steel or aluminum round pipe signposts. See table above for pipe sizes.
- All hardware items are American Standard sizes, galvanized in accordance with ASTM A153 (hot dipped) or ASTM B695 (mechanically applied).
- Fasteners, except for special bolt and coupling, are installed with lockwashers, and do not have specific torque requirements. Fasteners should be secured as tight as possible with conventional wrenches, unless noted otherwise.
- Square-up and level individual components, particularly Anchors to minimize the need for shimming between the Couplings and Anchors.
- No more than two shims shall be placed under any one coupling. No more than three shims underneath any pair of couplings.
- Refer to other side of page for complete installation instructions.

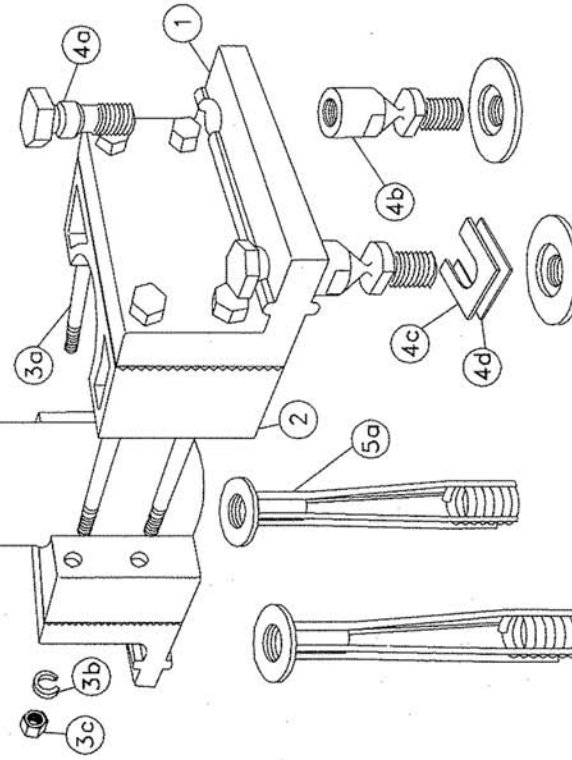

TRANSPO
INDUSTRIES, INC.
The Smart Solutions Company

20 Jones Street
New Rochelle, NY 10801
914-636-1000
www.transpo.com

Break-Safe Model AP
Breakaway Support System for Sign Posts

Scale: Not To Scale Date: July 2000
Drawing No. BS-AP-1 Sheet: 1 of 2

Patent Nos. 4,528,786 and 5,596,845

Note: Drawing scale shown on plans is accurate for full size plans only. AECOM is not responsible for scale discrepancies caused by reduced size plans.

Description:
Transpo Base Specifications

Original Issue Date: 2011.05.04

Revisions:

These drawings express visual design intent only. Final engineering, materials, and fabrication shall remain the responsibility of the fabricator.

The content of this document is subject to the design intent requirements outlined in the following sections: Fabricator Performance & Material Requirements, Quantities & Submittals, Materials & Finishes, and Fonts & Symbols.

Contact:
Environmental Graphics/Wayfinding
AECOM
407-843-6552
150 N Orange Avenue, Suite 200
Orlando, Florida 32801

Project Team:
JMM
SPC
DH

Drawn By: SPC

INSTALLATION INSTRUCTIONS

ANCHOR ASSEMBLY:

Note: Precise positioning of the anchors is critical to proper assembly of the system. It is recommended that actual posts be used to locate the correct position of the anchors.

1. Fabricate a flat, rigid template with four (4) 16mm (5/8") diameter holes located to match the specified anchor pattern of the Break-Safe Brackets attached to the signpost. See diagram below.

2. Attach four (4) Transpo Type A Female Anchors to the template using four (4) 16mm (5/8") diameter bolts. Ensure that each Anchor Washer is snug against the bottom of the template.

3. Lower Anchor Assembly into fresh concrete foundation, and vibrate into position such that the tops of the Anchor Washers are flush with the finished top surface of the foundation. Support the template such that all Anchors are level and in their proper locations.

4. Allow concrete to cure, and then remove the bolts and template from the top of the foundation.

BRACKET ASSEMBLY:

1. Place Bracket Adaptors and Brackets squarely on the bottom of the post, such that the lower end of the post is flush with the bottom of both Bracket Adaptors.

2. Secure the Bracket assembly with bolts, lock washers, and nuts. Then, tighten all 1/2 turn beyond snug.

COUPLING ASSEMBLY:

1. Thread four (4) Break-Safe Couplings into Anchors. Do not tighten.

2. Suspend post assembly over foundation, insert Special Bolts through holes in the Brackets, and thread them snug into the Couplings.

3. If post is not plumb, insert Shims (14g and/or 18g) between the Couplings and Anchors, where needed.

4. Use lower wrench flats to tighten Couplings into Anchors as tight as possible using a conventional wrench. Do not use a pipe wrench. Couplings must be seated squarely.

5. Tighten Special Bolts while holding Couplings by the upper wrench flats with an additional wrench to prevent an induced torque stress across the necked portion of the Coupling. All Special Bolts shall also be tightened as tight as possible using conventional wrenches.

SIGN PANEL ASSEMBLY:

1. After all signposts are secured in place, attach sign panel assembly to posts in accordance with the sign manufacturer's recommendations.

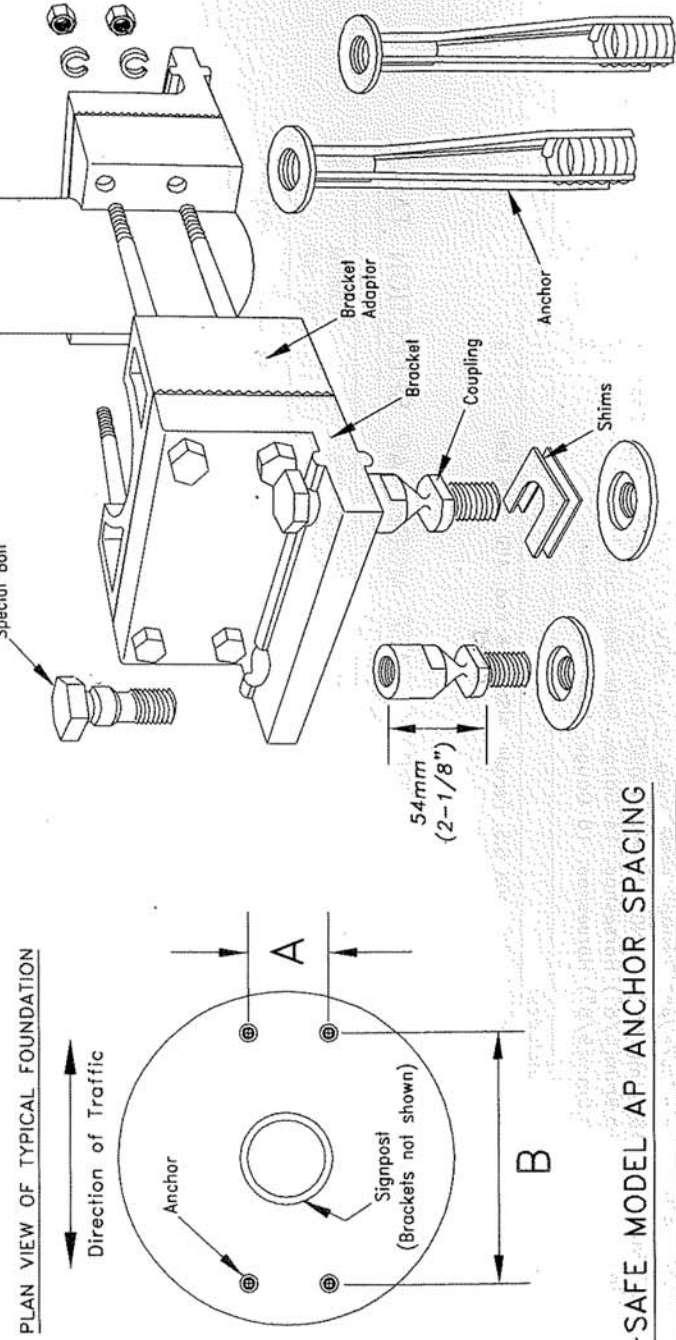

BREAK-SAFE MODEL AP ANCHOR SPACING

BREAK-SAFE MODEL	POST OUTSIDE DIAMETER (D)	NOMINAL PIPE SIZE	A	B
AP3	76 mm (3")	64 mm (2-1/2")	57 mm (2-1/4")	189 mm (7-7/16")
AP3.5	89 mm (3-1/2")	76 mm (3")	70 mm (2-3/4")	202 mm (7-15/16")
AP4	102 mm (4")	89 mm (3-1/2")	83 mm (3-1/4")	227 mm (8-15/16")
AP4.5	114 mm (4-1/2")	102 mm (4")	83 mm (3-1/4")	227 mm (8-15/16")

TRANSPO
INDUSTRIES, INC.
The Smart Solutions Company

20 Jones Street
New Rochelle, NY 10801
914-636-1000
www.transpo.com

Break-Safe Model AP
Breakaway Support System for Sign Posts

Scale: Not To Scale Date: July 2000

Drawing No. BS-AP-2 Sheet: 2 of 2

Patent Nos. 4,528,786 and 5,596,845

Note: Drawing scale shown on plans is accurate for full size plans only. AECOM is not responsible for scale discrepancies caused by reduced size plans.

Description:
Transpo Base Specifications

Original Issue Date: 2011.05.04

Revisions:

These drawings express visual design intent only. Final engineering, materials, and fabrication shall remain the responsibility of the fabricator.

The content of this document is subject to the design intent requirements outlined in the following sections: Fabricator Performance & Material Requirements, Quantities & Submittals, Materials & Finishes, and Fonts & Symbols.

Contact:
Environmental Graphics/Wayfinding
AECOM
407-843-6552
150 N Orange Avenue, Suite 200
Orlando, Florida 32801

Project Team:
JMM
SPC
DH

Drawn By: SPC

SIGN REMOVAL PLAN



LEGEND

- 1** TO BE REMOVED
Removals Recommended by AECOM and Approved by WSDOT
- 1** TO REMAIN
Removals Recommended by AECOM but Requested to Remain by WSDOT
- *** Includes Pole Removal



1



2



3



4



5



6



7



8



9



10

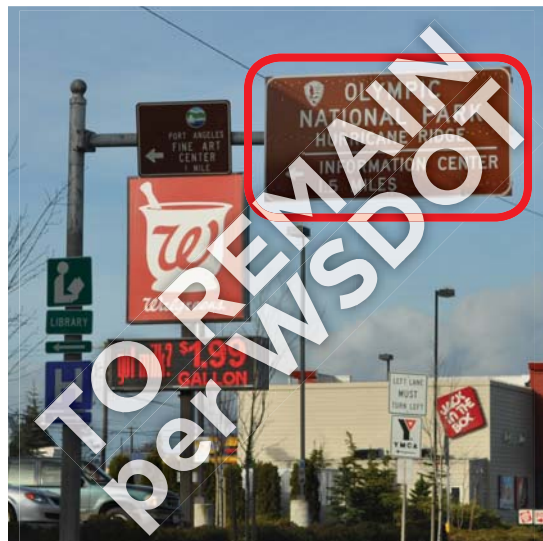

11

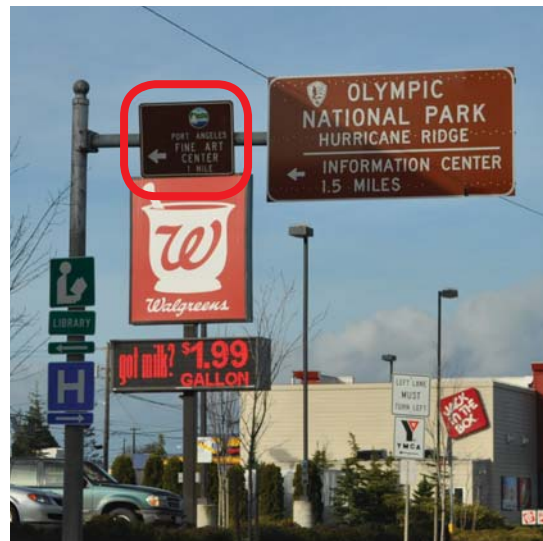

12

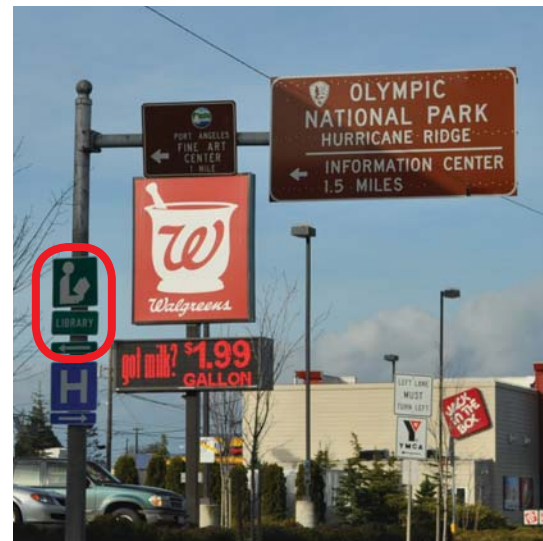

13



14



15



16



17



18

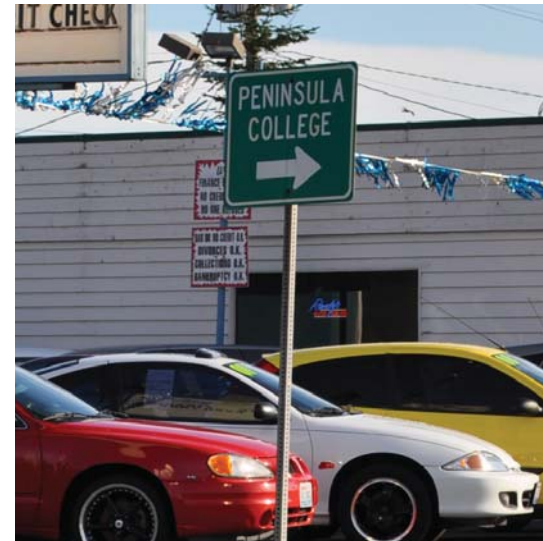

19

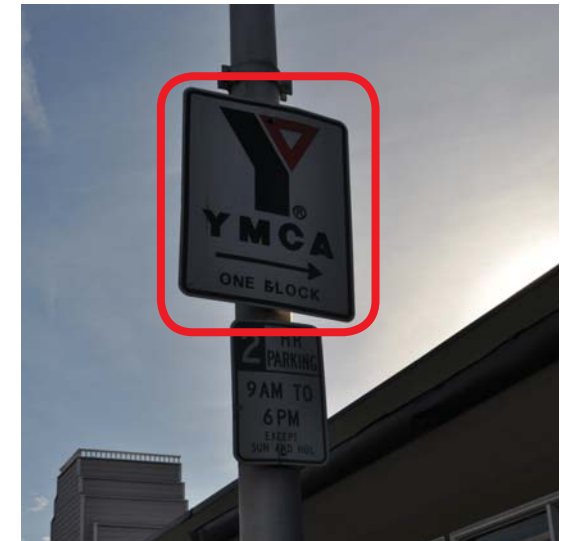

20



21

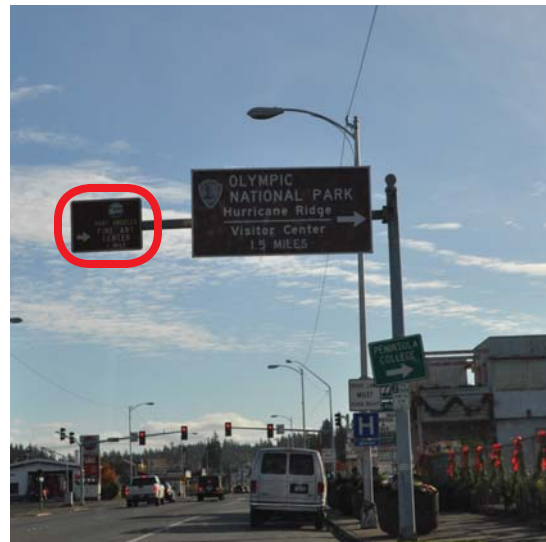

22



23

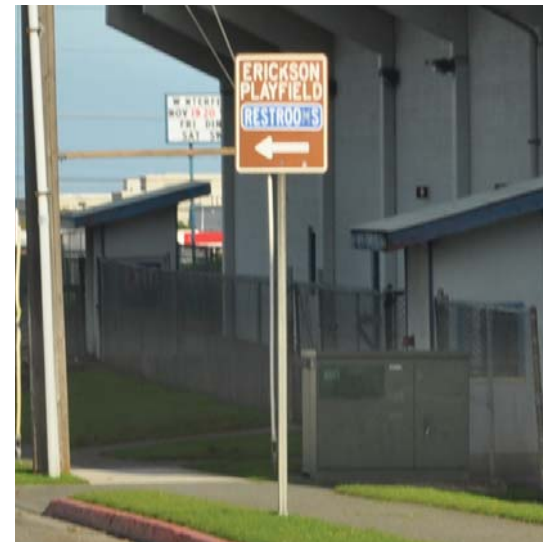

24

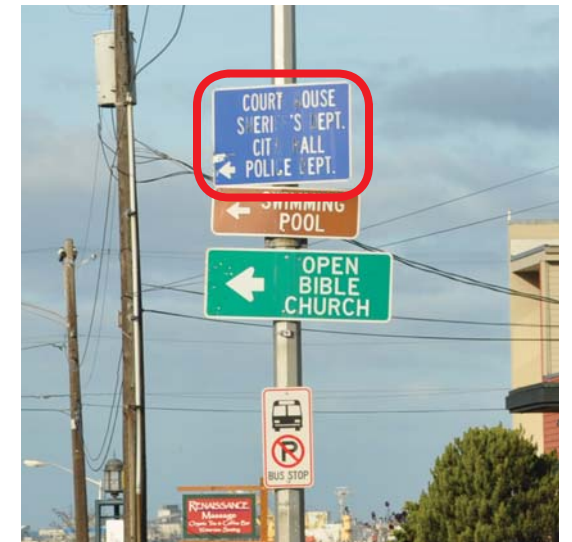

25



26

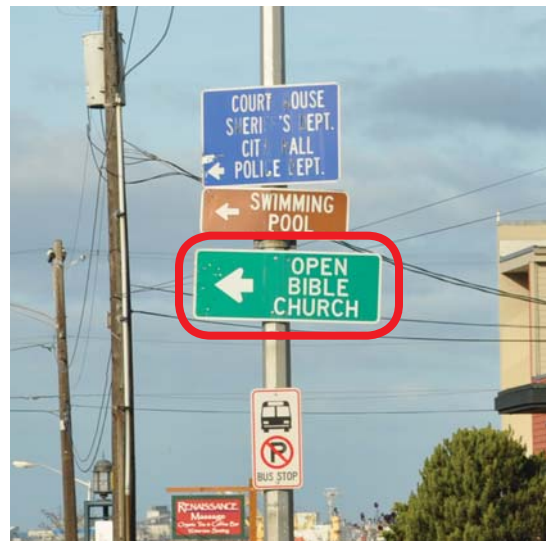

27



28



29



30



31



32



33



34



35



36

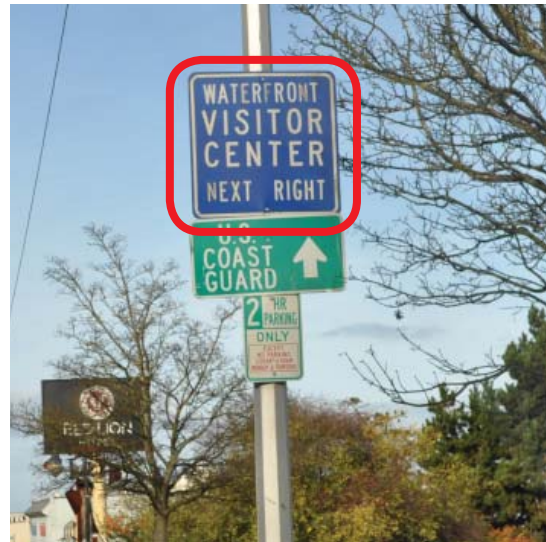

37



38



39



40



41



42



43



44



45



46

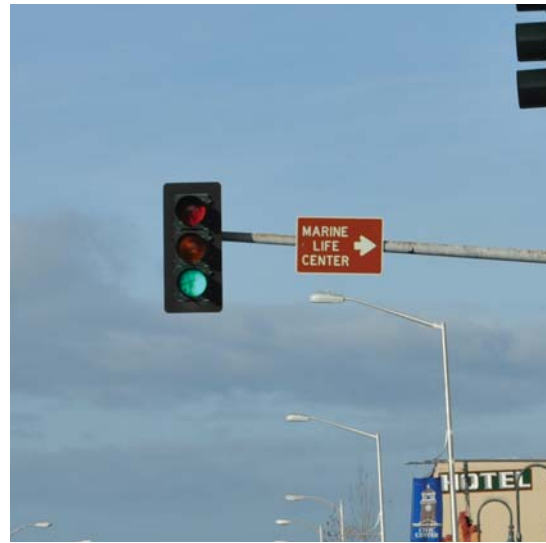

47



48



49



50



51 Note: For Sign 51, replace large, existing pole with smaller one for East 101 sign.

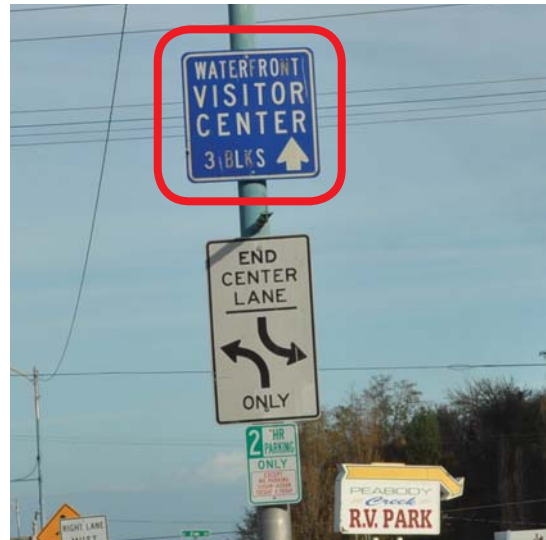

52



53



54



55



56



57



58



59



60



61



62



63



64



65



66



67



68



69



70



71



72



73



74



75



76



77



78

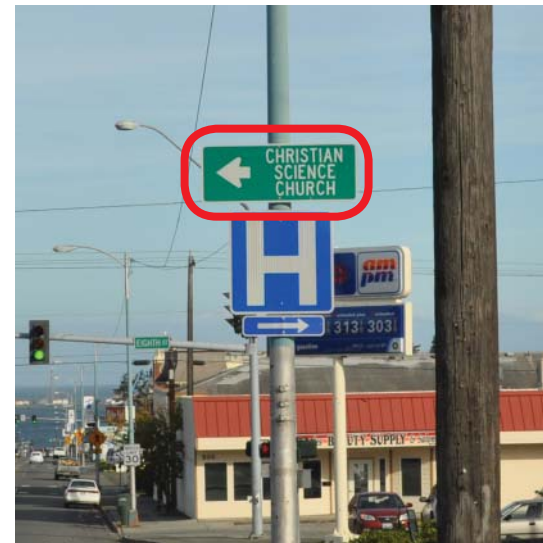

79



80



81



82



83



84



85



86



87



88



89



90



91



92



93



94



95



96



97



98

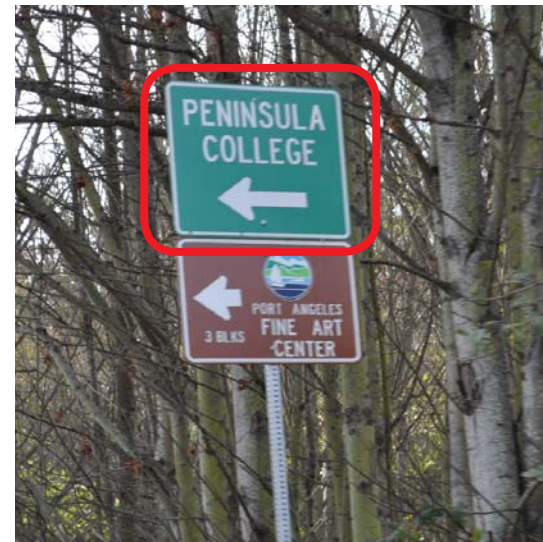

99



100



101



102



103

SIGN LOCATION PLAN for WSDOT VEHICULAR DIRECTIONAL SIGNS
(Sign Type A)



SIGN LOCATION FIELD VERIFICATION — Sign Type A



1

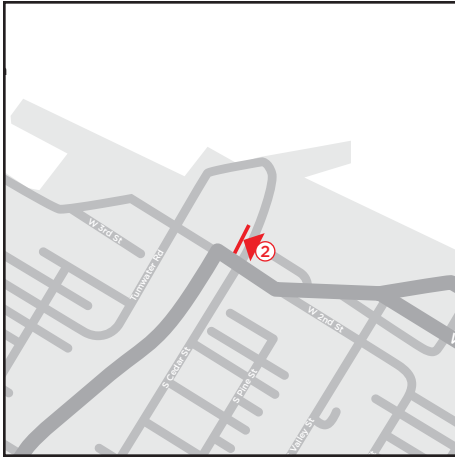

2

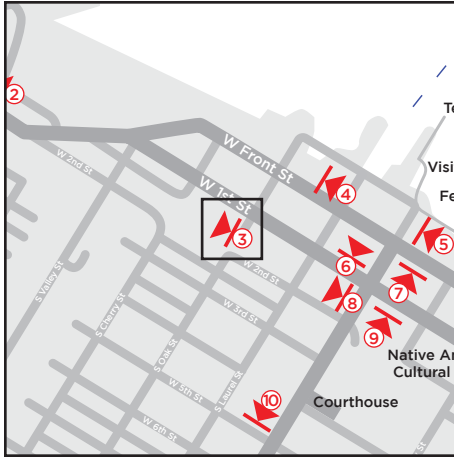

3

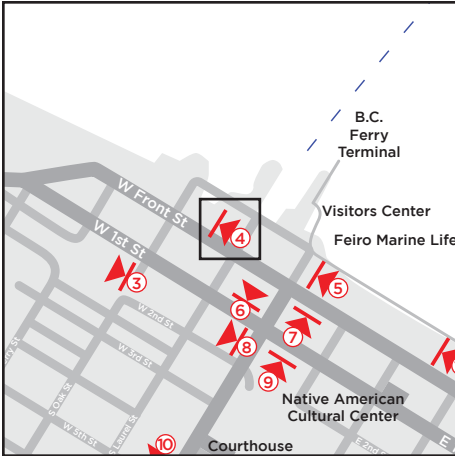

4

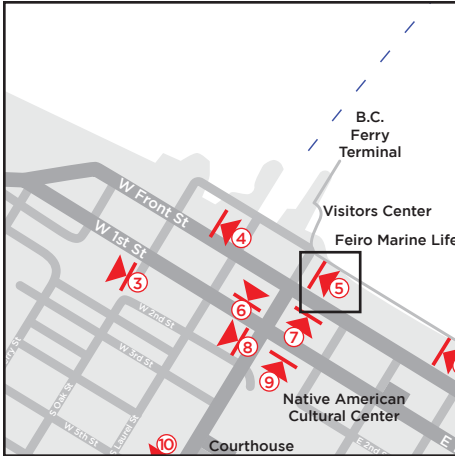

5

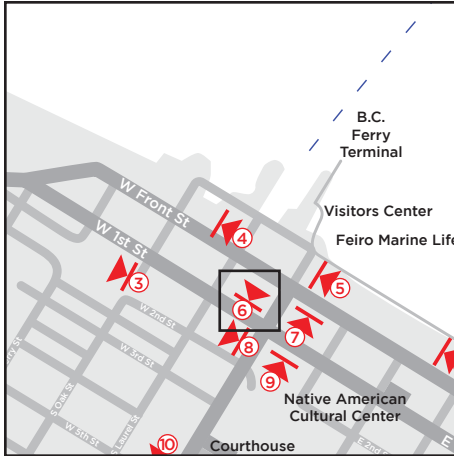

6

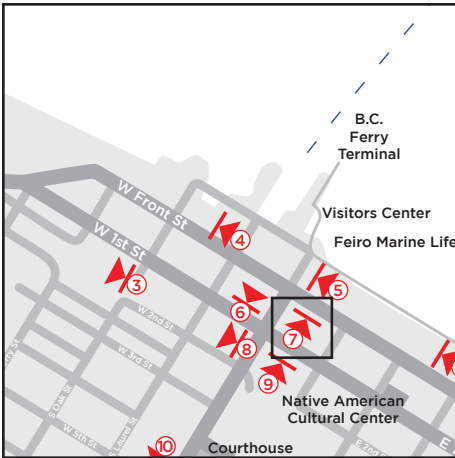

7

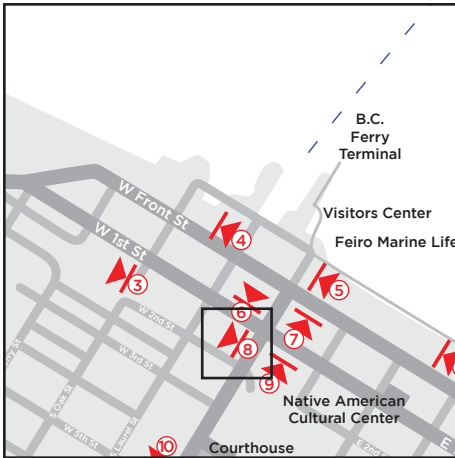

8

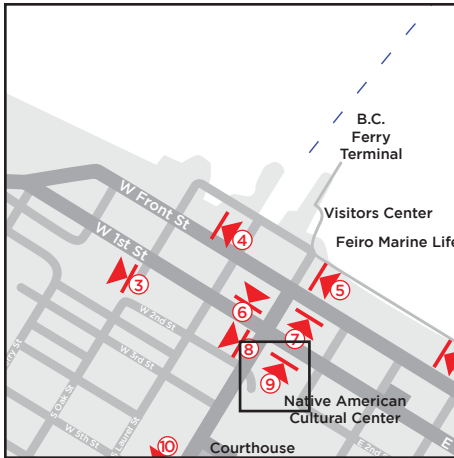

9

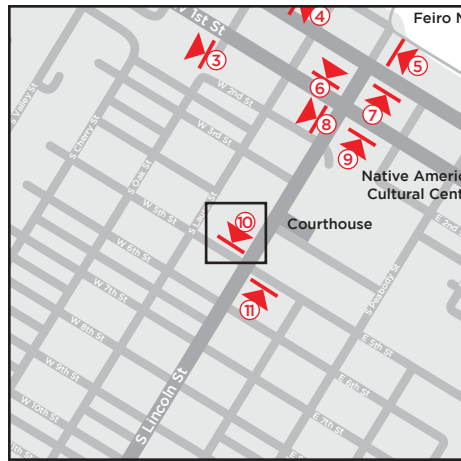

10

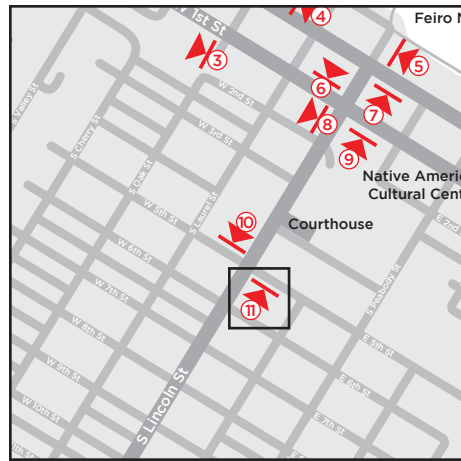

11

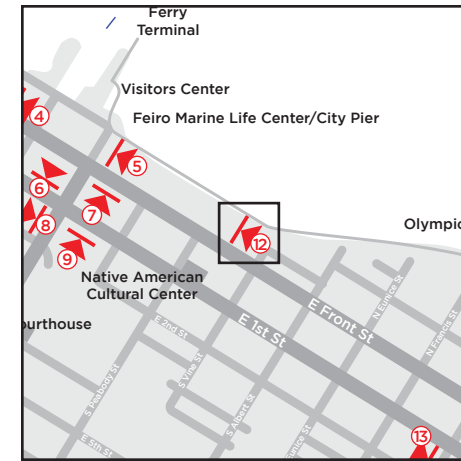

12

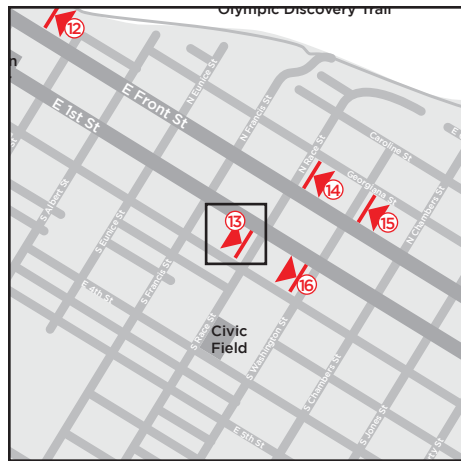

13

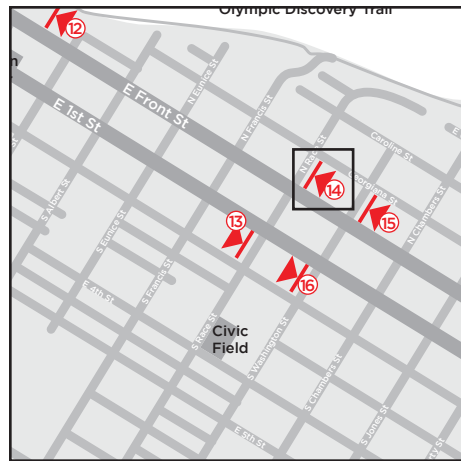

14

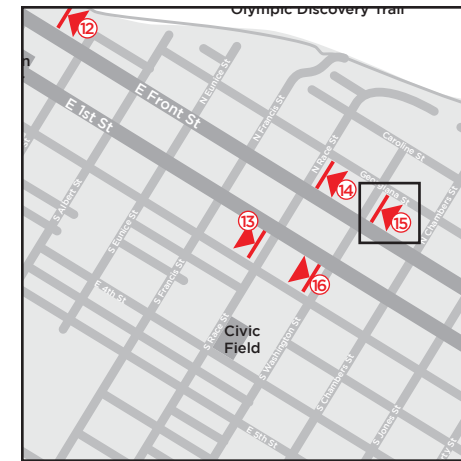

15

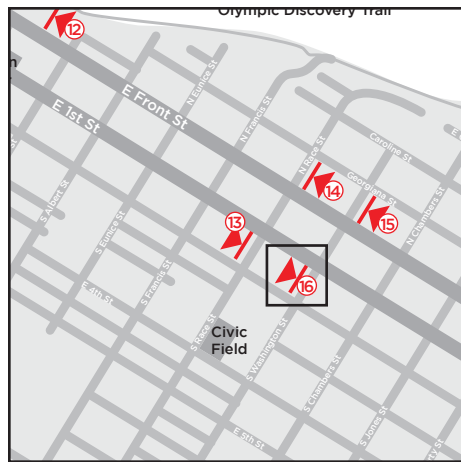

16



17

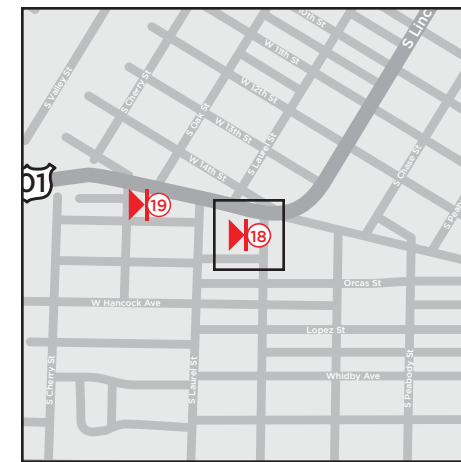

18

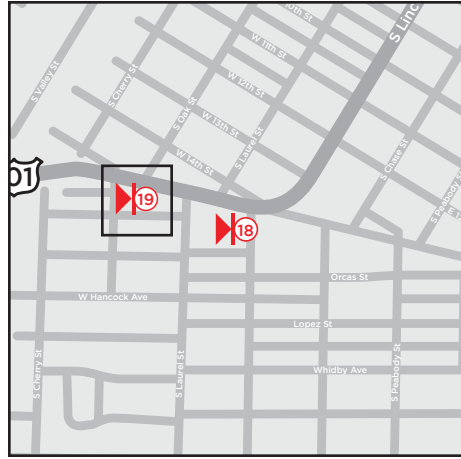

19

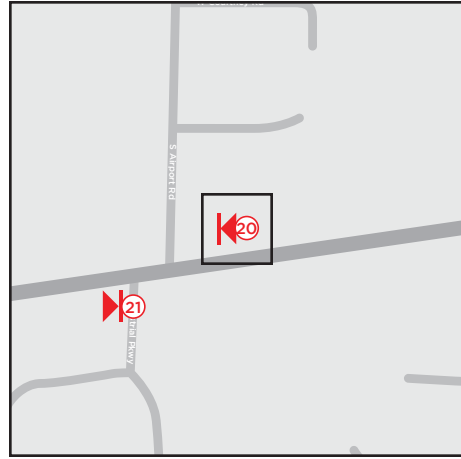

20

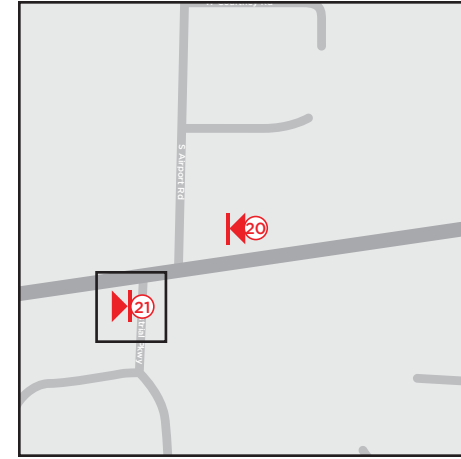

21

SIGN LOCATION PLAN for VEHICULAR DIRECTIONAL SIGNS
(Sign Type B)



SIGN LOCATION FIELD VERIFICATION — Sign Type B

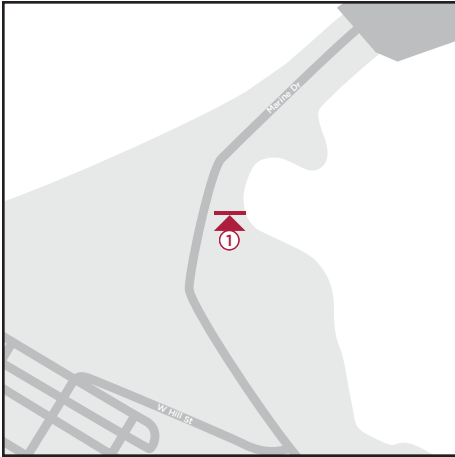

1



2

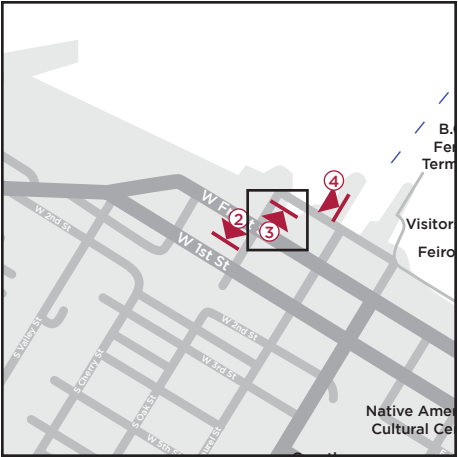

3

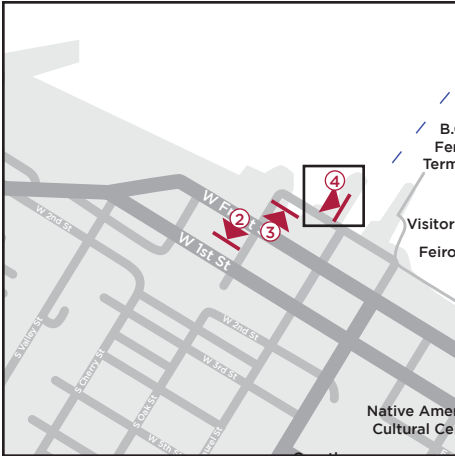

4

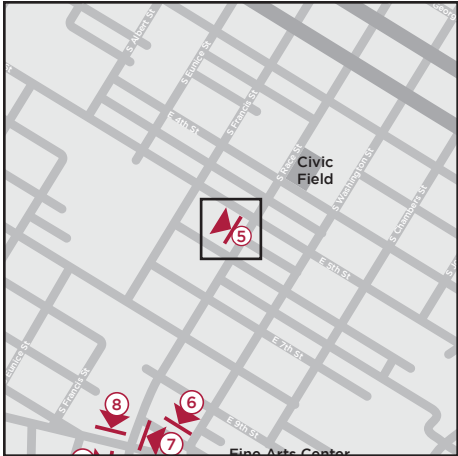

5

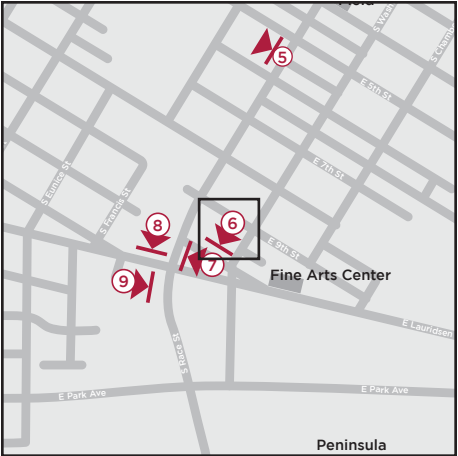

6

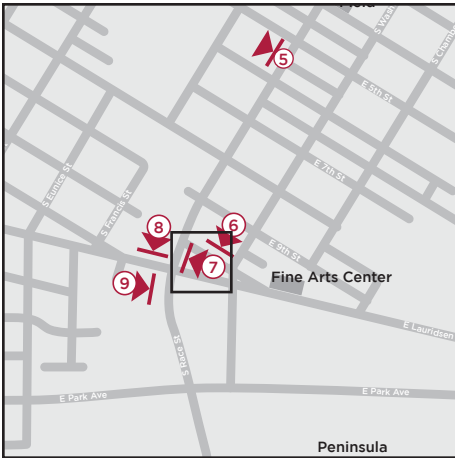

7

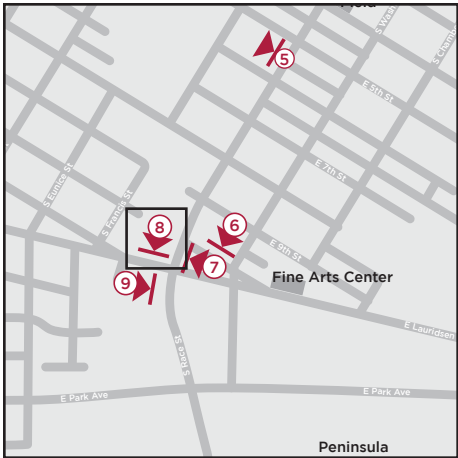

8

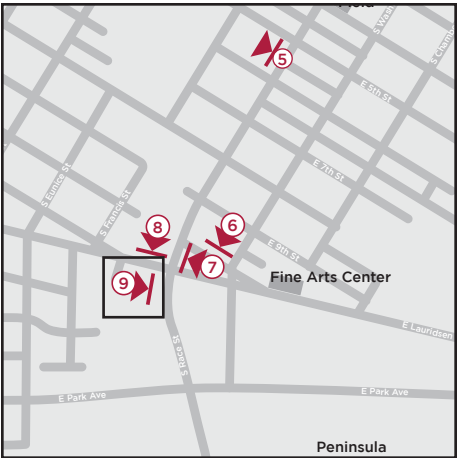

9

SIGN LOCATION PLAN for PEDESTRIAN DIRECTIONAL SIGNS
(Sign Type C)



SIGN LOCATION FIELD VERIFICATION — Sign Type C

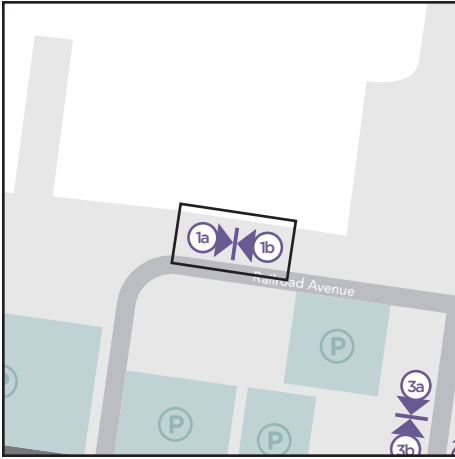

1

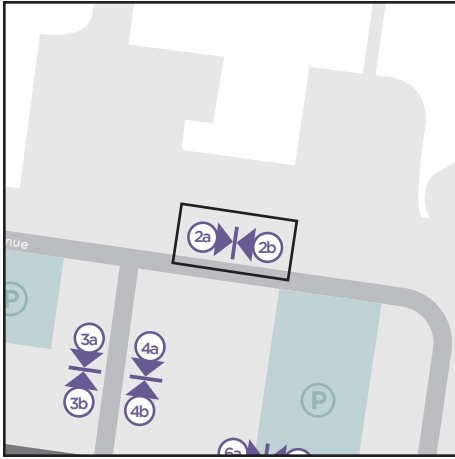

2



3



4

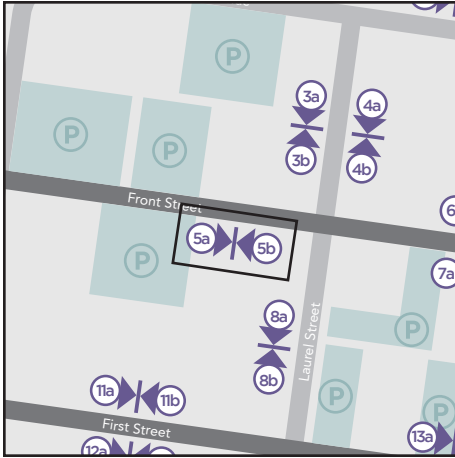

5



6



7



8

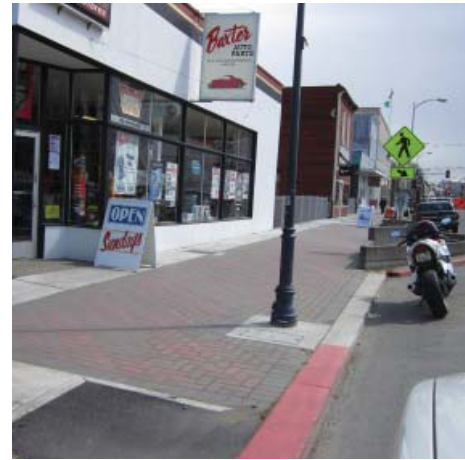

9

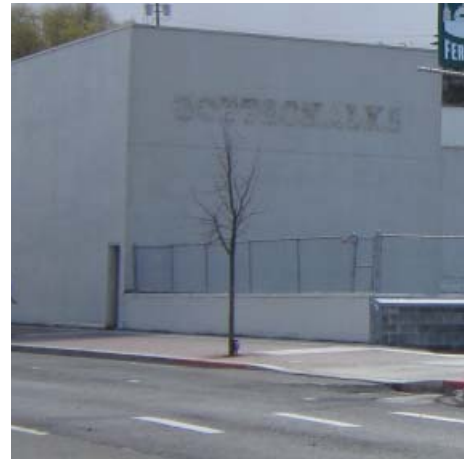

10

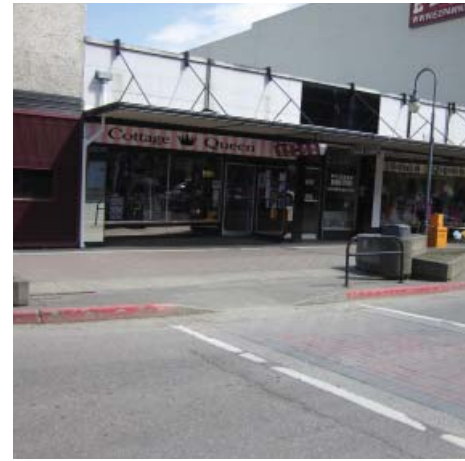
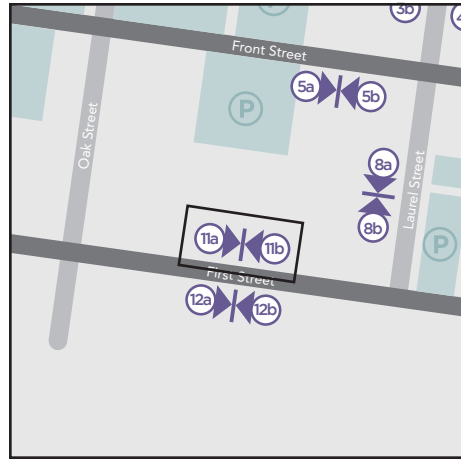

11



12

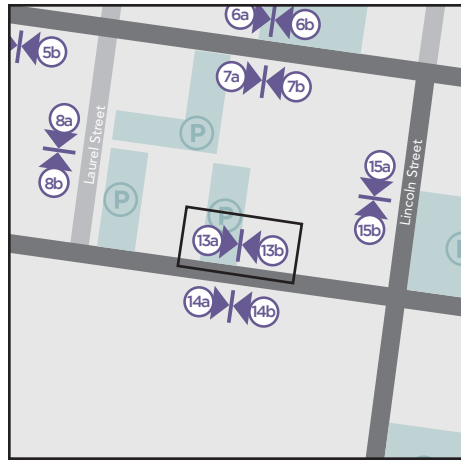

13

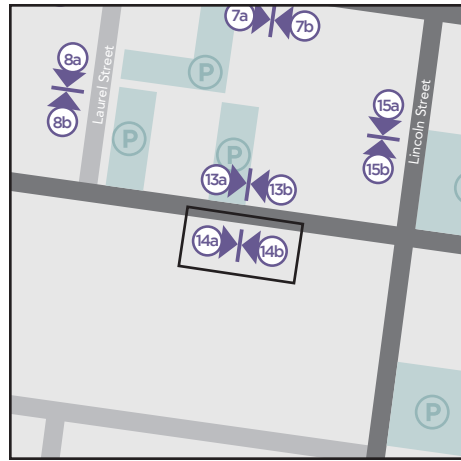

14

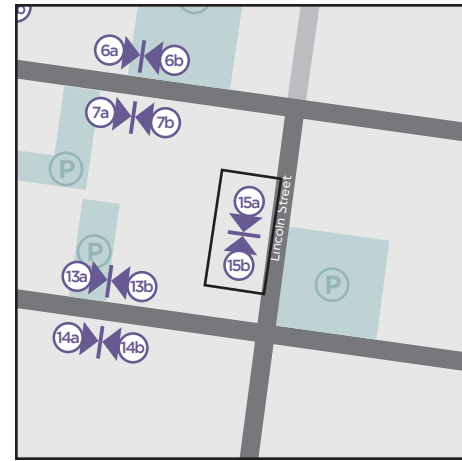

15

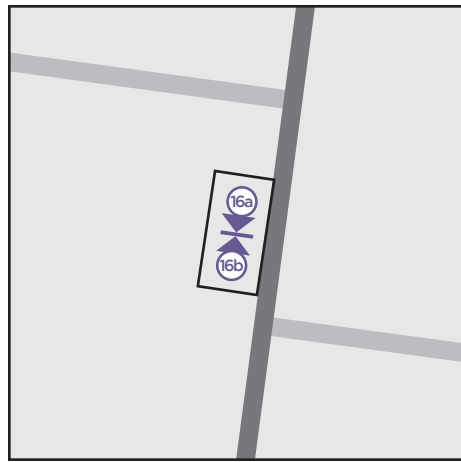

16

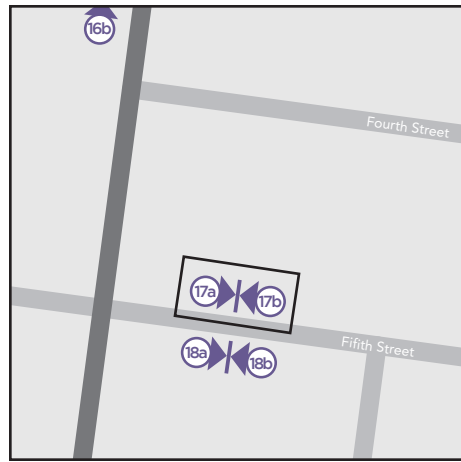

17

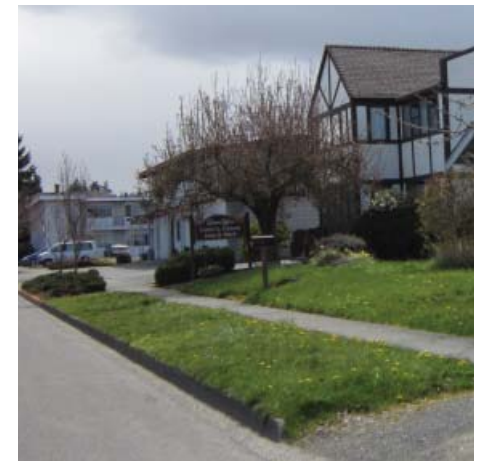
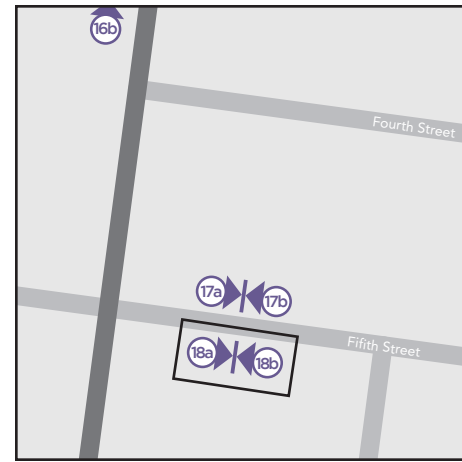

18

SIGN LOCATION PLAN for PARKING ID SIGNS
(Sign Type D-1)



SIGN LOCATION FIELD VERIFICATION — Sign Type D-1

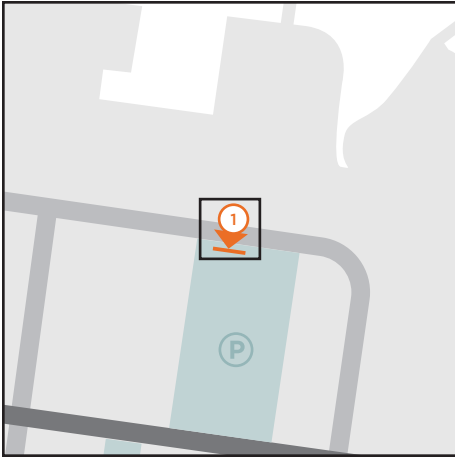

1

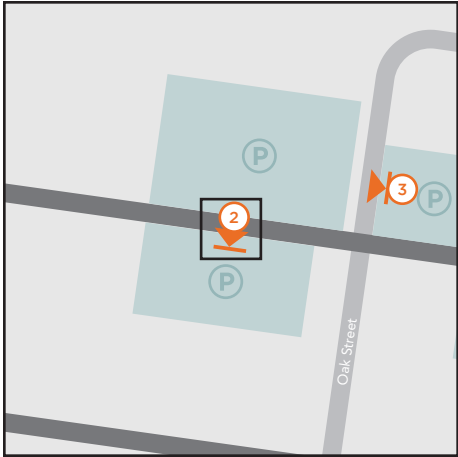

2



3

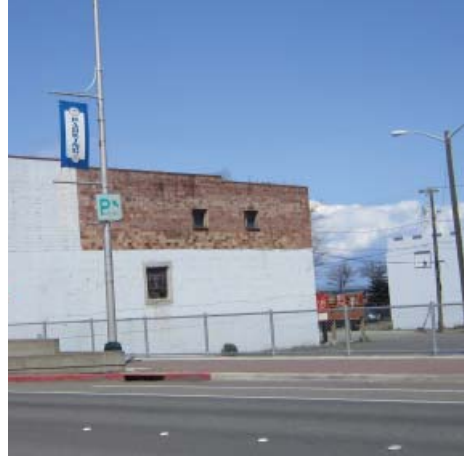
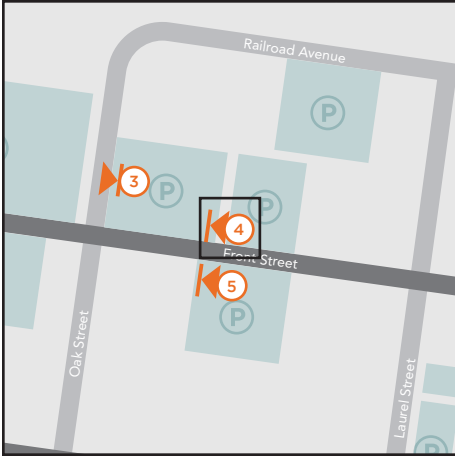

4

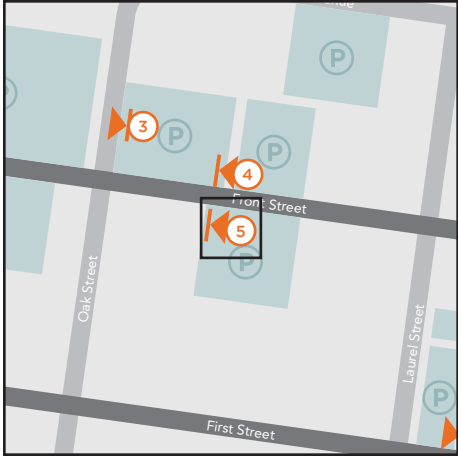

5

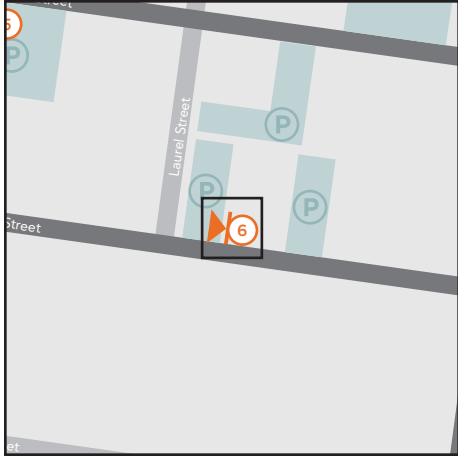

6

SIGN LOCATION PLAN for PARKING ID SIGNS with MAP
(Sign Type D-2)



SIGN LOCATION FIELD VERIFICATION — Sign Type D-2



1

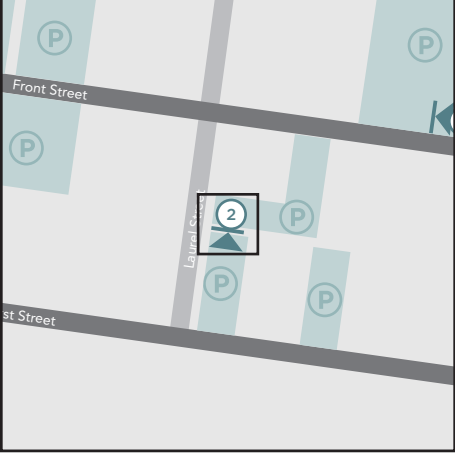

2

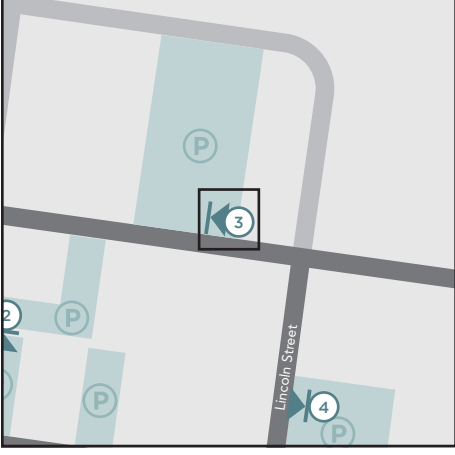

3

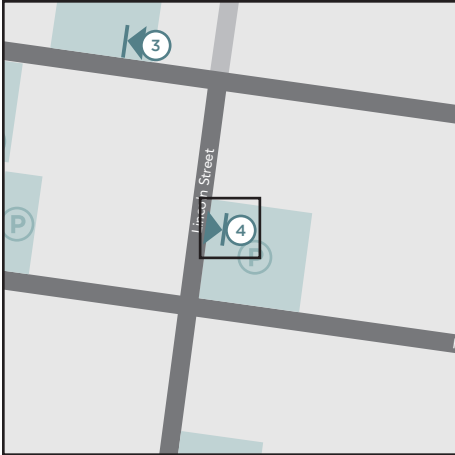

4

SIGN LOCATION PLAN for PEDESTRIAN KIOSK MAP
(Sign Type E)



SIGN LOCATION FIELD VERIFICATION — Sign Type E

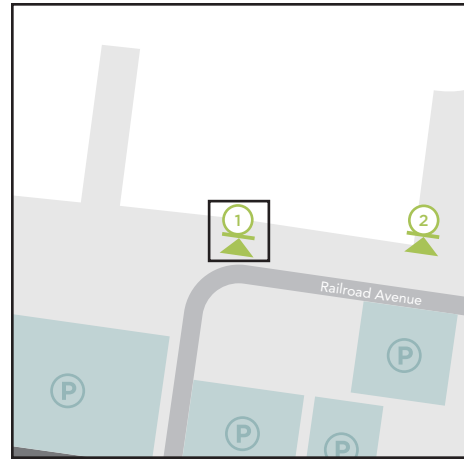

1

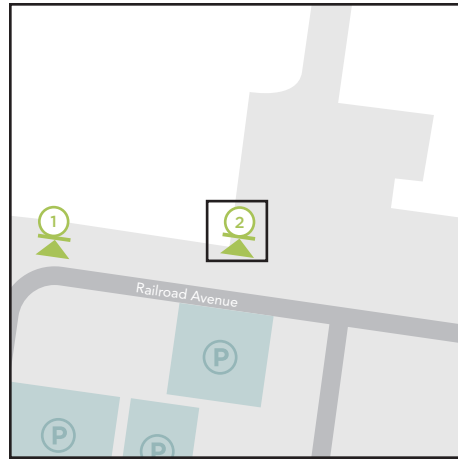

2

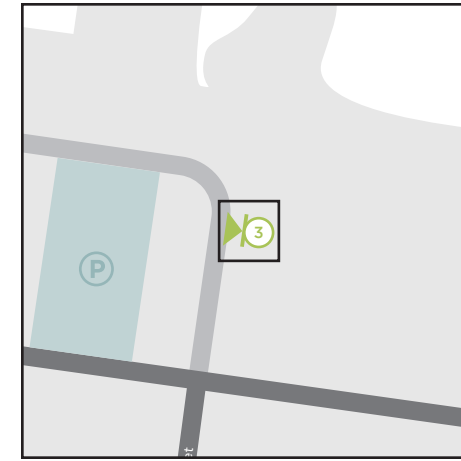

3

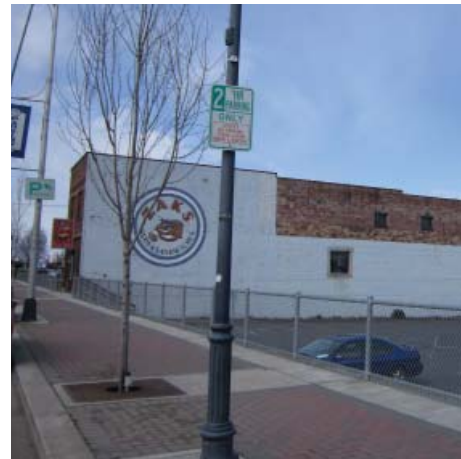
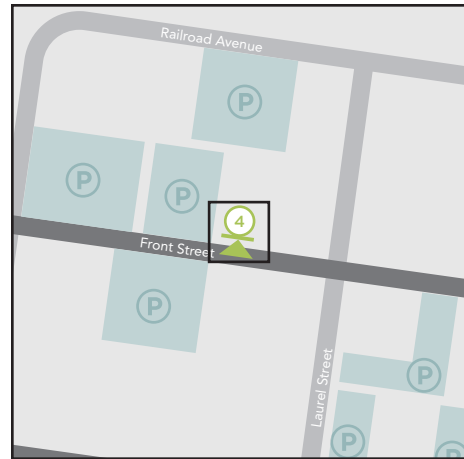

4

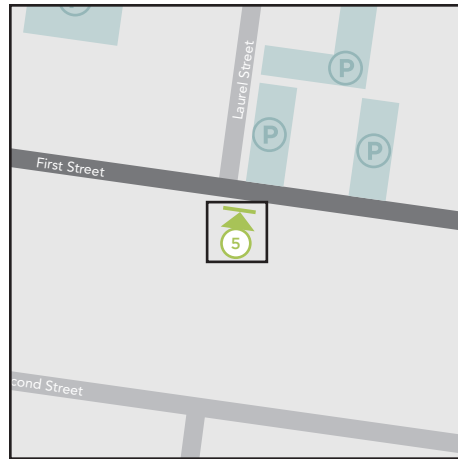

5

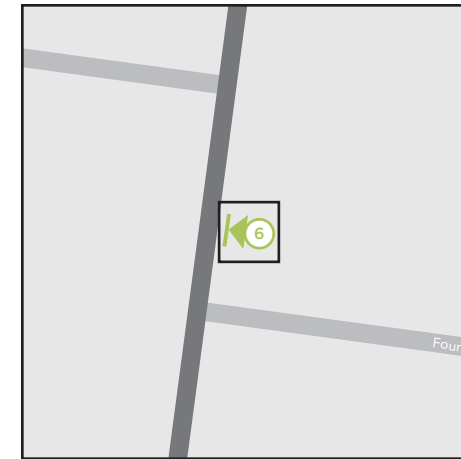

6

SIGN LOCATION PLAN for HISTORIC DISTRICT
(Sign Type F)



SIGN LOCATION FIELD VERIFICATION — Sign Type F

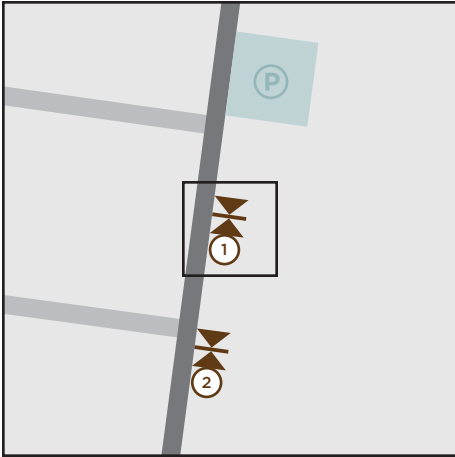

1

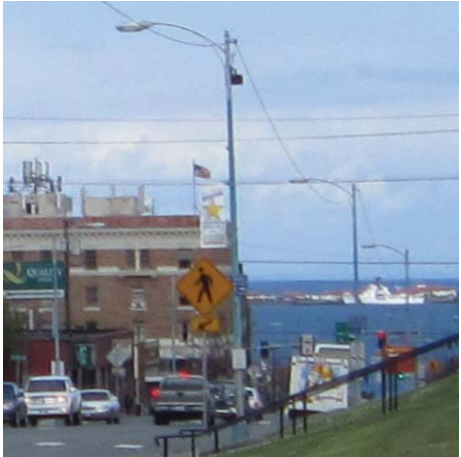
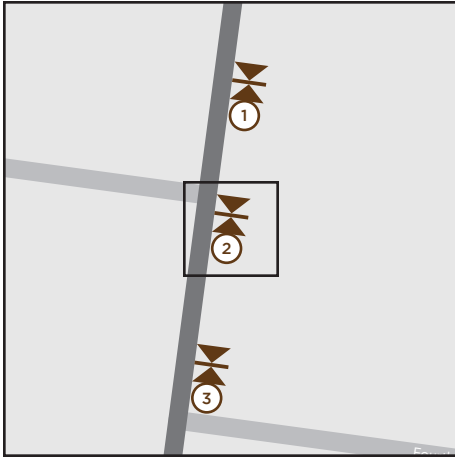

2

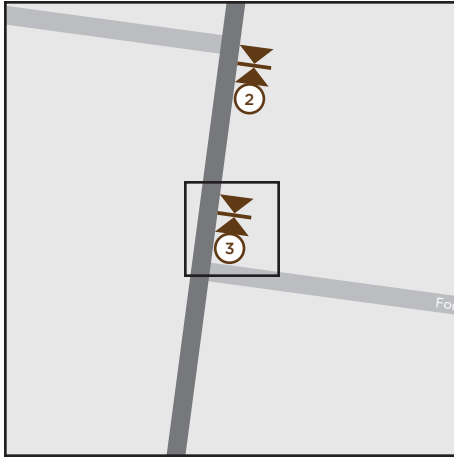

3

SIGN LOCATION PLAN for TSUNAMI EVACUATION ROUTE
(Sign Type G-1)

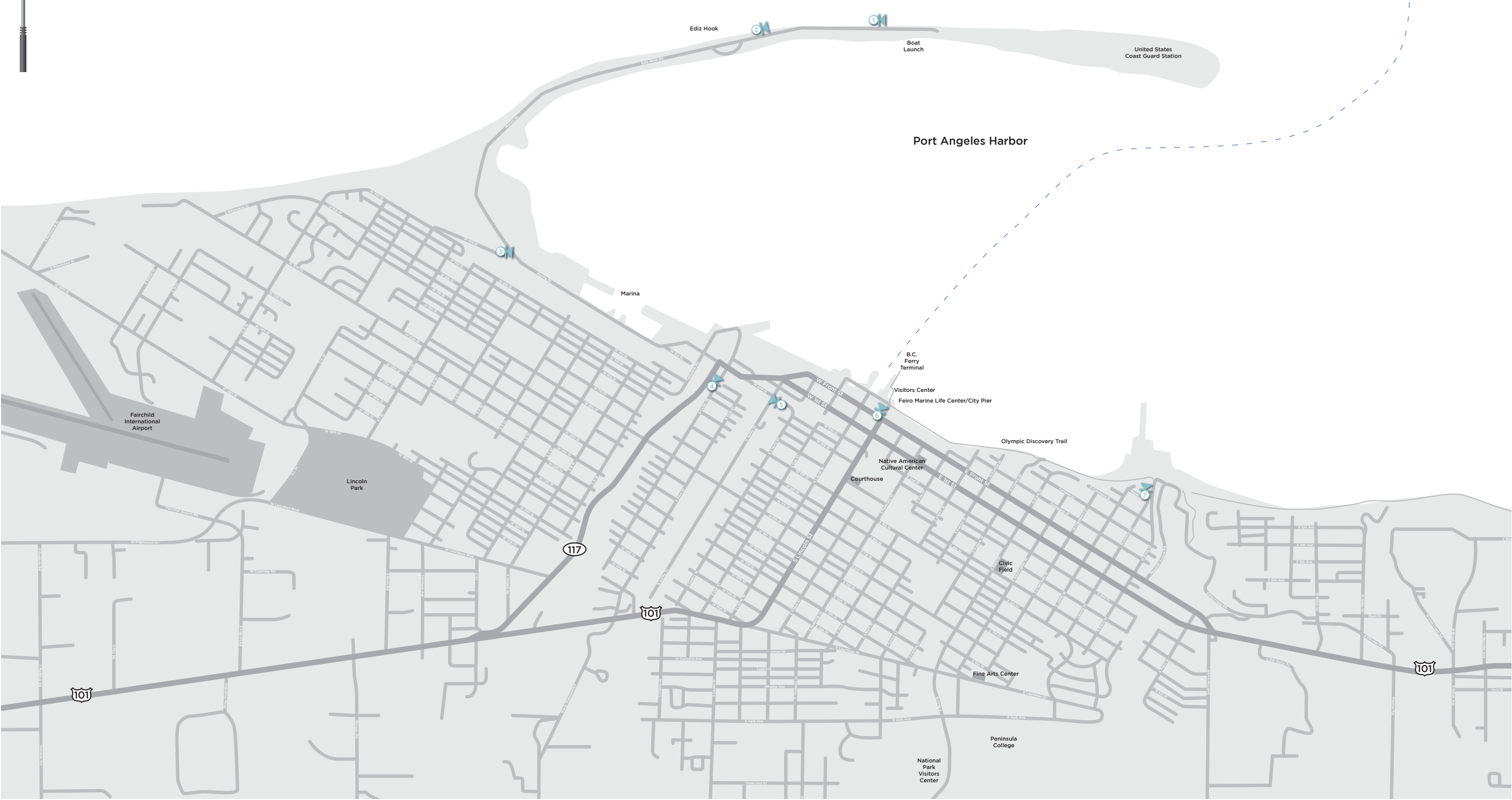

SIGN LOCATION PLAN for TSUNAMI EVACUATION ROUTE
(Sign Type G-2)

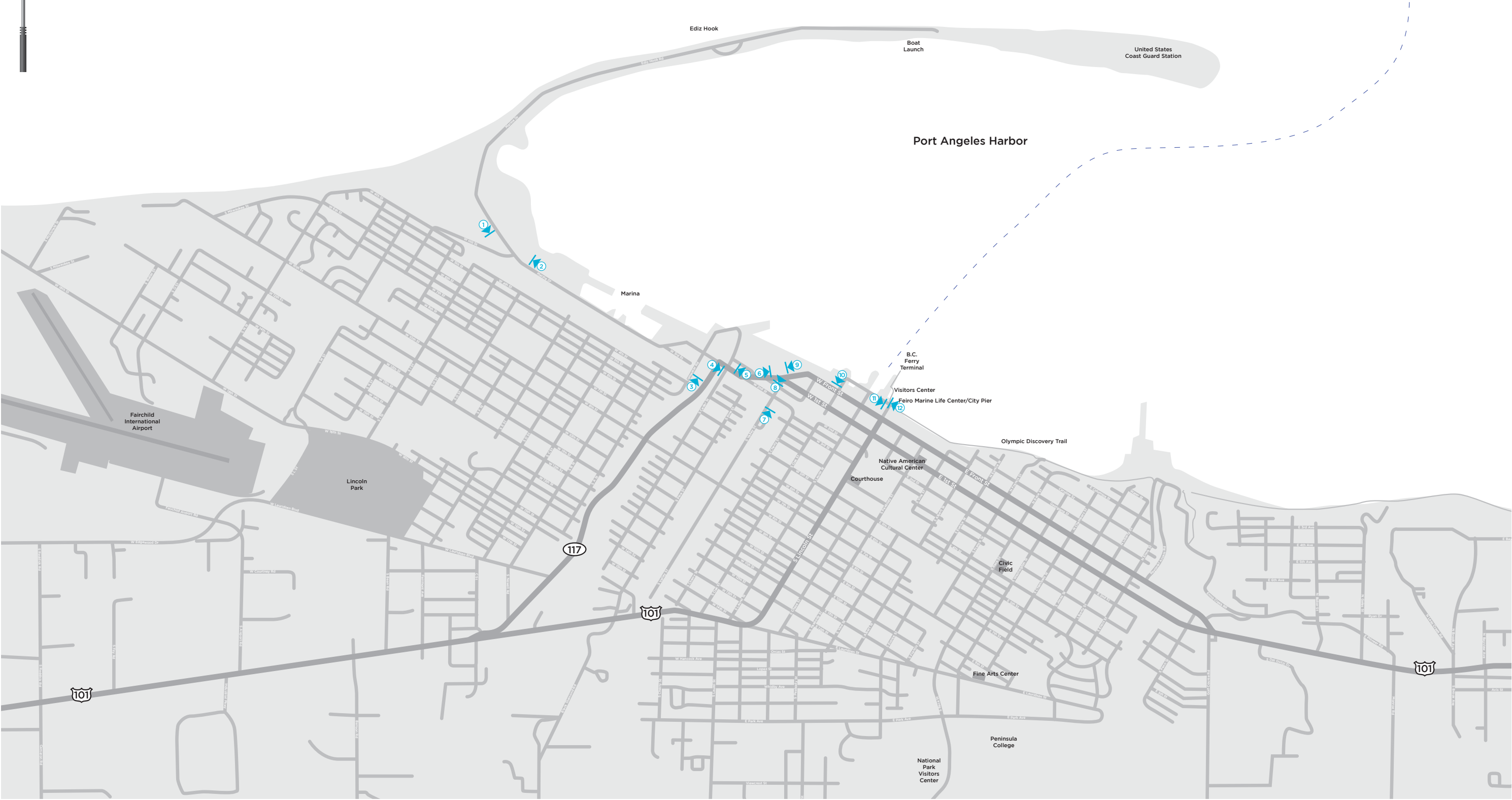

SIGN LOCATION PLAN for PROTOTYPES
(Phase 1)



Scale: NTS

Note: Drawing scale shown on plans is accurate for full size plans only. AECOM is not responsible for scale discrepancies caused by reduced size plans.

Description:
Sign Placement Guideline

Original Issue Date: 2011.01.07

Revisions: 2011.01.25

These drawings express visual design intent only. Final engineering, materials, and fabrication shall remain the responsibility of the fabricator.

The content of this document is subject to the design intent requirements outlined in the following sections: Fabricator Performance & Material Requirements, Quantities & Submittals, Materials & Finishes, and Fonts & Symbols.

Contact:
Environmental Graphics/Wayfinding
AECOM
407-843-6552
150 N Orange Avenue, Suite 200
Orlando, Florida 32801

Project Team:
JMM
SPC
DMH

Drawn By: SPC

Figure 1
Sign Type A and B
Vehicular Directional

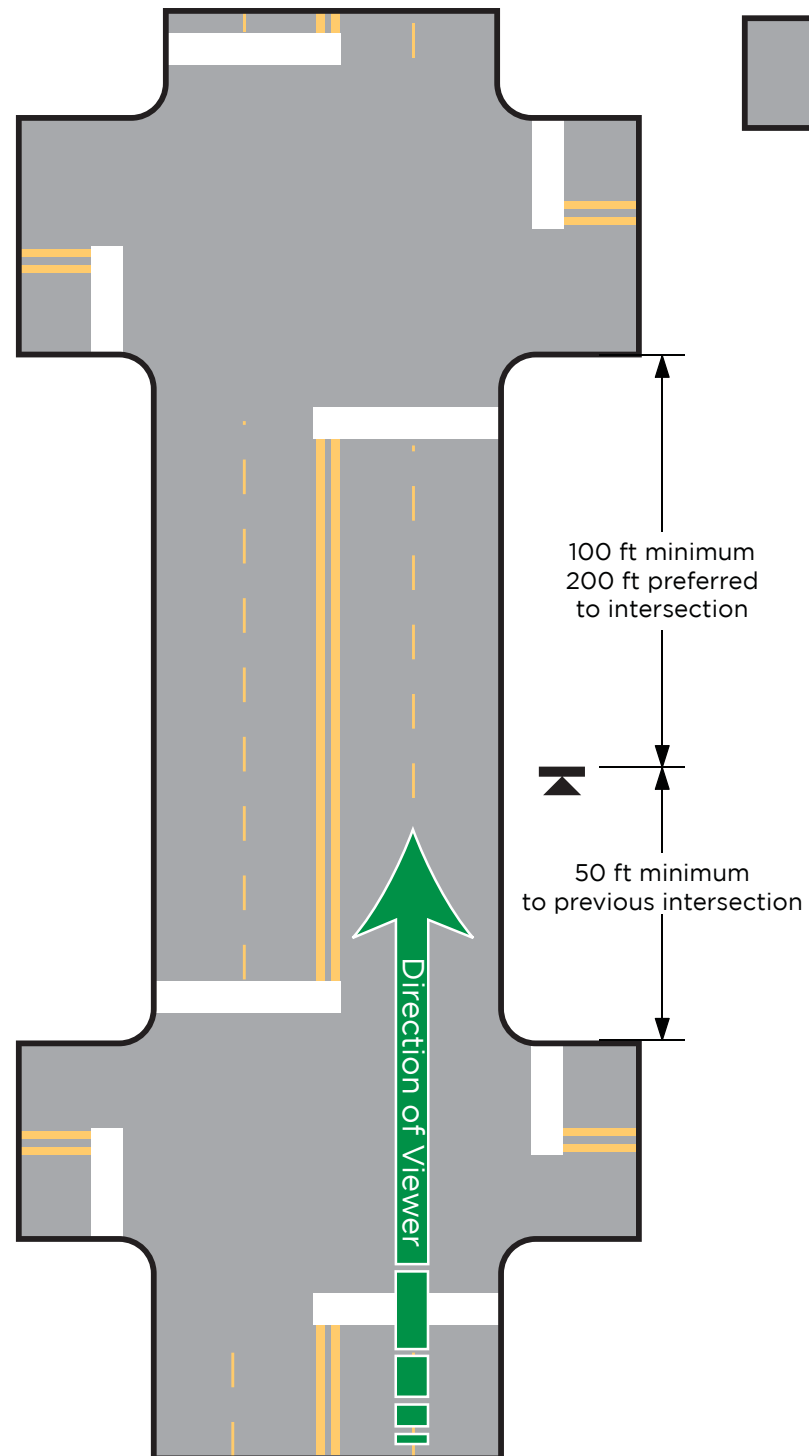

Figure 2
Sign Type A and B
Vehicular Directional with turn lane

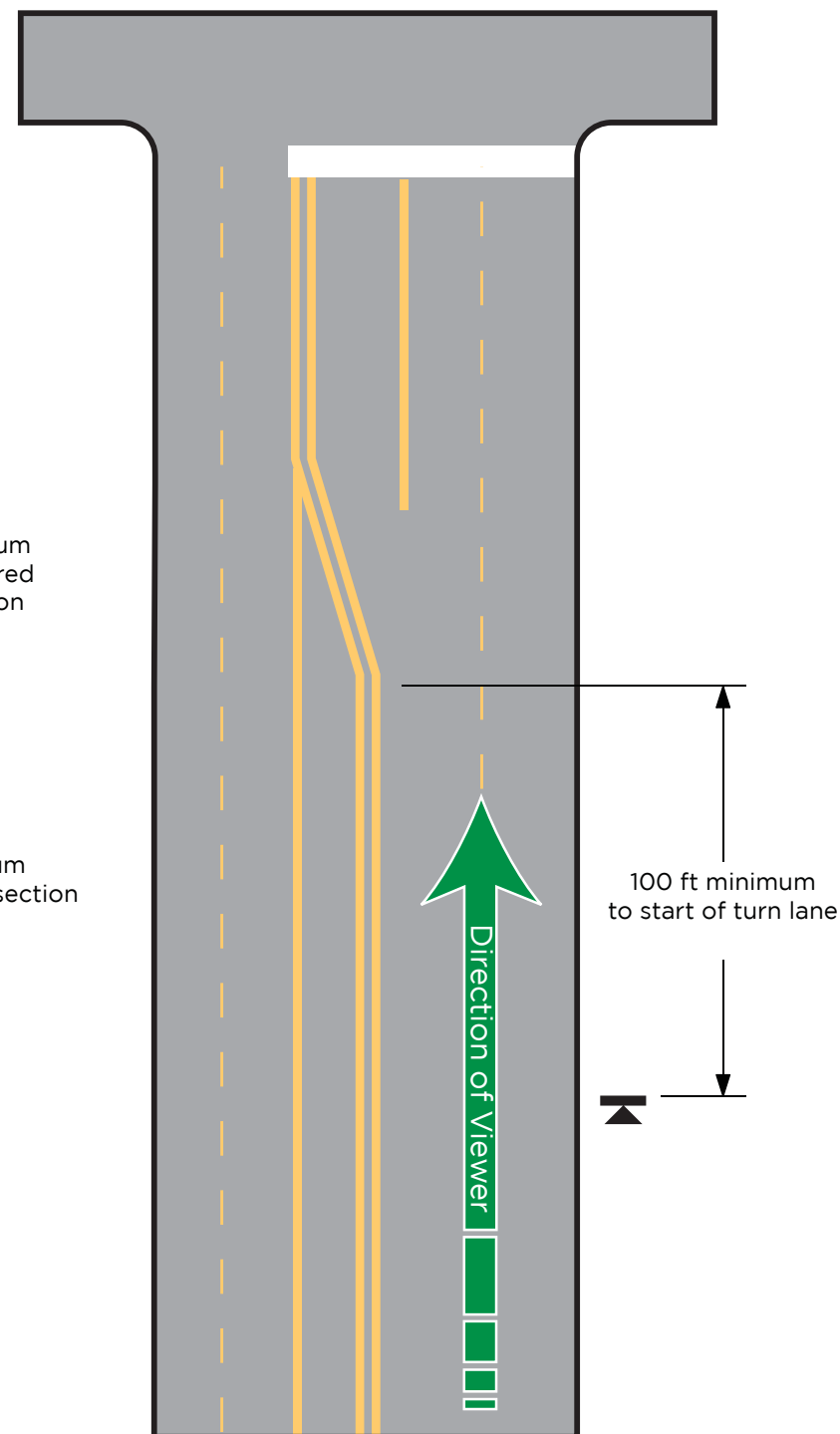
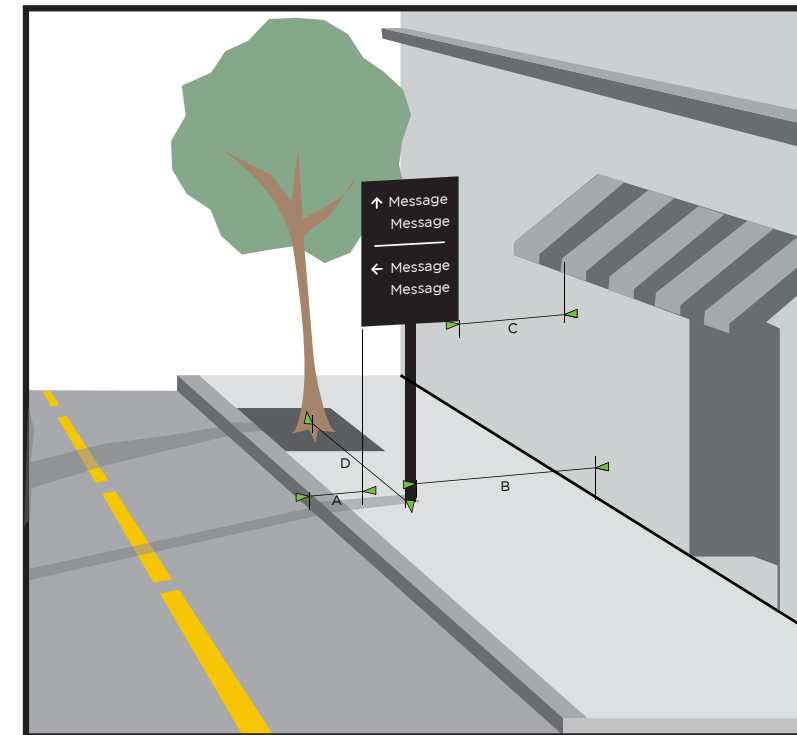

Figure 3
All Sign Types



Note	Description	Distance Preferred	Distance Minimum
A	Distance from edge of sign panel to edge of curb	24 in	18 in
B	Distance from post to nearest obstruction	4 ft	3 ft
C	Distance from edge of sign to nearest overhead obstruction	4 ft	1 ft
D	Distance from post to utility pole of tree	8 ft	3 ft

Measurements and distances listed in the above figure serve as a guideline and shall not supersede state or municipal codes.

Super Destinations

Downtown
 Ferries
 National Park

Top Destinations

Airport
 Lincoln Park
 Marina
 Boat Launch
 Visitors Center
 Marine Life Center
 Courthouse
 Civic Field
 Ediz Hook
 Native American Cultural Center
 Fine Arts Center
 Peninsula College
 Coast Guard
 Historic District
 Clallum County Fairgrounds
 Composite Campus

Suggested Abbreviations

Downtown
 Ferries
 National Park

 Airport
 Lincoln Park
 Marina
 Boat Launch
 Visitors Ctr
 Marine Ctr
 Courthouse
 Civic Field
 Ediz Hook
 Cultural Ctr
 Fine Arts Ctr
 College
 Coast Guard
 Historic District
 Fairgrounds
 Campus

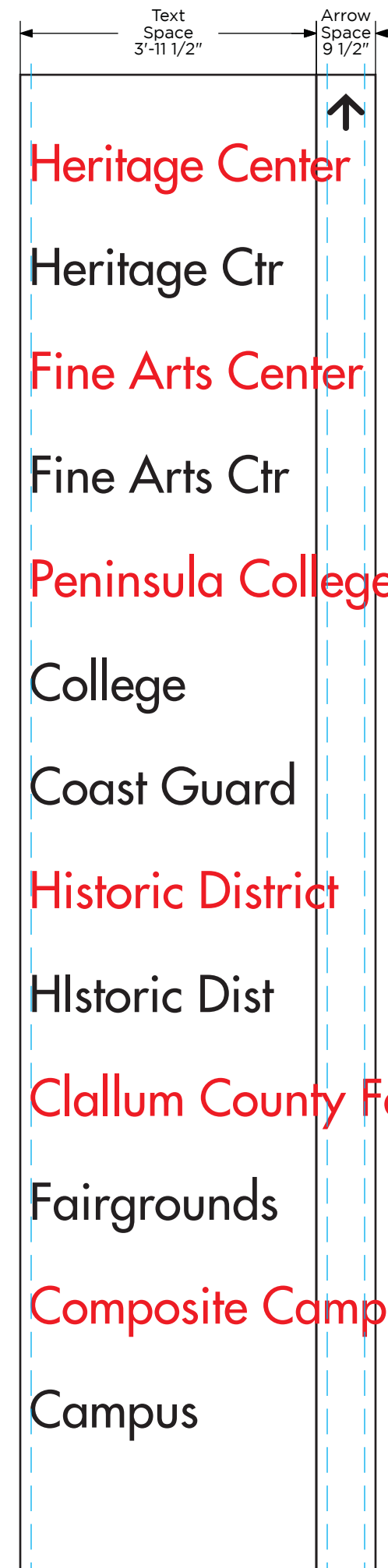
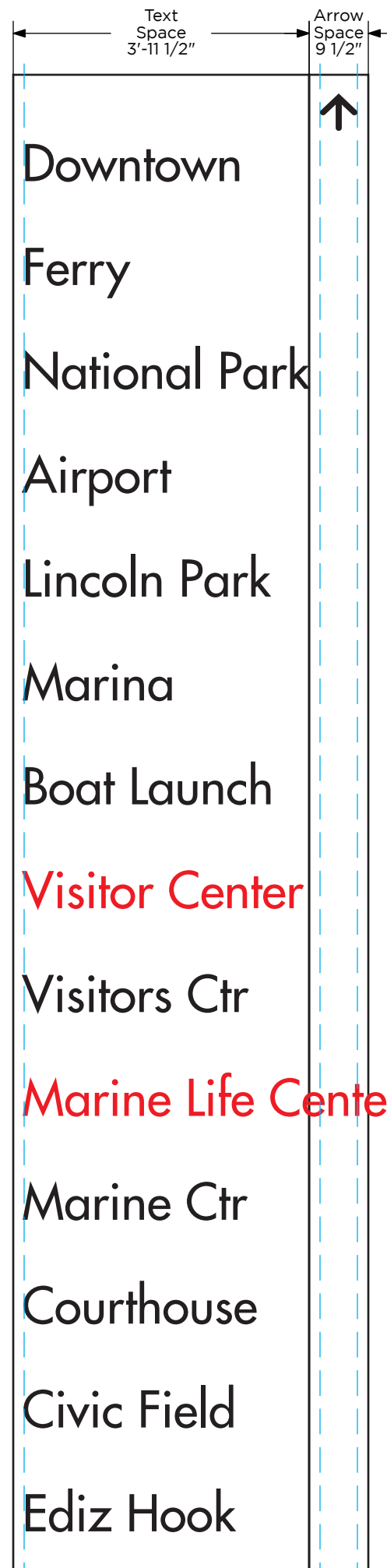

Scale: NTS

Note: Drawing scale shown on plans is accurate for full size plans only. AECOM is not responsible for scale discrepancies caused by reduced size plans.

Description: Sign Messages
 Destination Matrix for Vehicular Directional

Original Issue Date: 2011.01.28

Revisions: 2011.02.22
 2011.03.10

These drawings express visual design intent only. Final engineering, materials, and fabrication shall remain the responsibility of the fabricator.

The content of this document is subject to the design intent requirements outlined in the following sections: Fabricator Performance & Material Requirements, Quantities & Submittals, Materials & Finishes, and Fonts & Symbols.

Contact:
 Environmental Graphics/Wayfinding
 AECOM
 407-843-6552
 150 N Orange Avenue, Suite 200
 Orlando, Florida 32801

Project Team:
 JMM
 SPC
 DMH

Drawn By: SPC

Other Destinations

Peninsula High School
Carnegie Library
~~Swimming Pool~~
City Pier
City Hall

Walkable Downtown

Destinations for Kiosks

Shopping
Dining/Coffee
Lodging
Waterfront Trail
City Pier/Park
Kayak Launch
Laurel stairs
Theater
Historic District/Museum

Suggested Abbreviations

High School
Carnegie
Pool
City Pier
City Hall

Shopping
Dining
Lodging
Trail
City Pier/Park
Kayak Launch
Laurel Stairs
Theater
Hist Museum

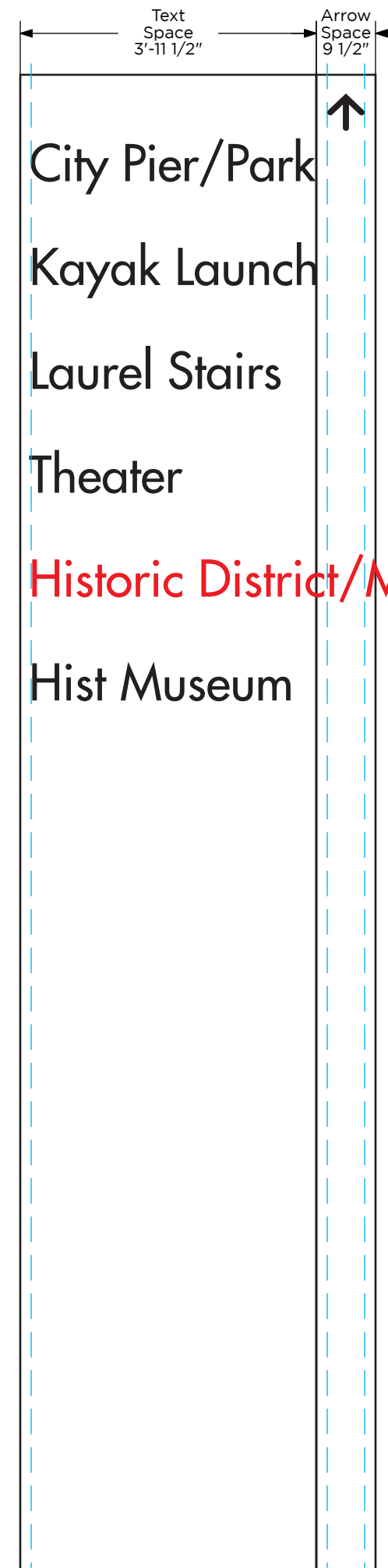

Scale: NTS

Note: Drawing scale shown on plans is accurate for full size plans only. AECOM is not responsible for scale discrepancies caused by reduced size plans.

Description: Sign Messages
Destination Matrix for Vehicular Directional

Original Issue Date: 2011.01.28

Revisions: 2011.02.22
2011.03.10

These drawings express visual design intent only. Final engineering, materials, and fabrication shall remain the responsibility of the fabricator.

The content of this document is subject to the design intent requirements outlined in the following sections: Fabricator Performance & Material Requirements, Quantities & Submittals, Materials & Finishes, and Fonts & Symbols.

Contact:
Environmental Graphics/Wayfinding
AECOM
407-843-6552
150 N Orange Avenue, Suite 200
Orlando, Florida 32801

Project Team:
JMM
SPC
DMH

Drawn By: SPC

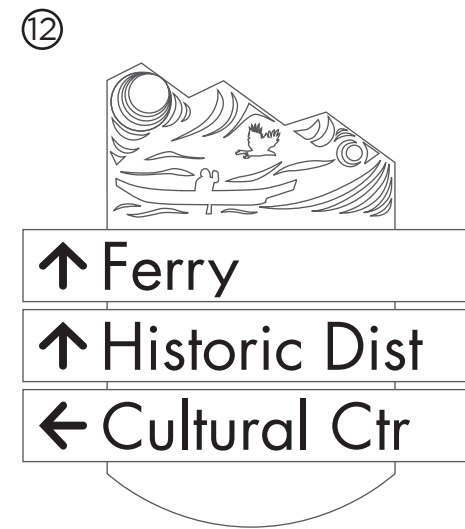
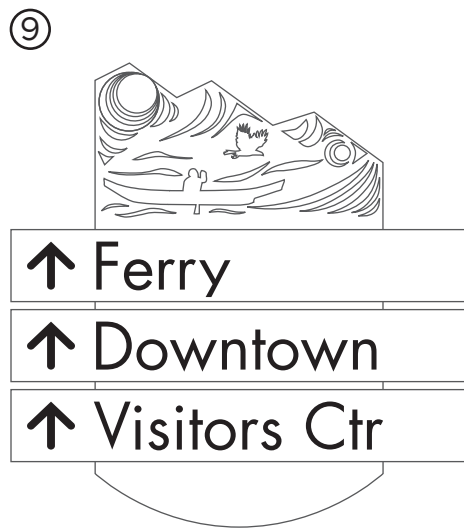
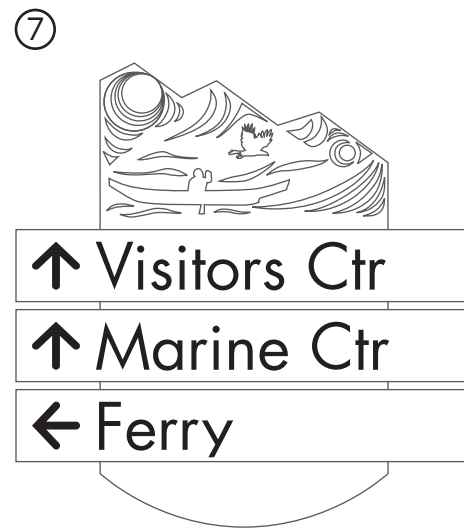
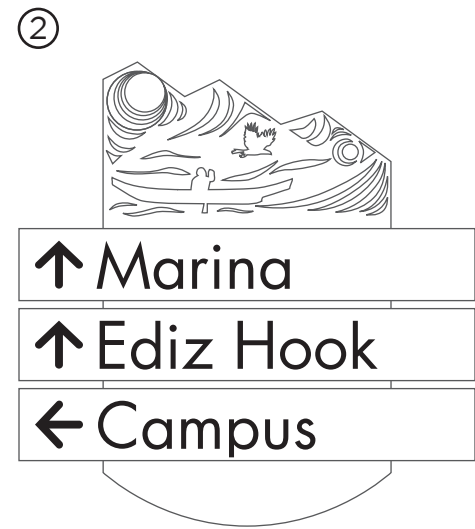
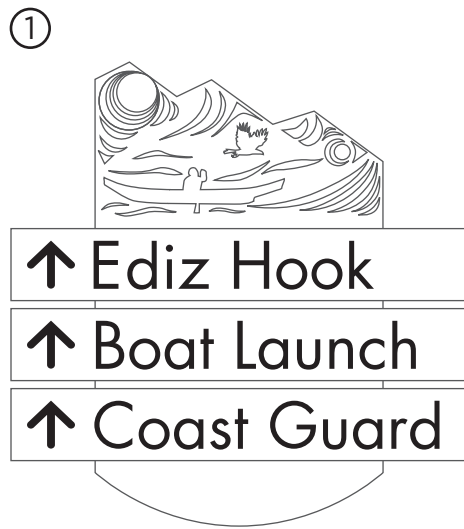

Scale: 1/2" = 1'

Note: Drawing scale shown on plans is accurate for full size plans only. AECOM is not responsible for scale discrepancies caused by reduced size plans.

Description: Sign Messages
WSDOT Vehicular Directional

Original Issue Date: 2011.01.28

Revisions: 2011.03.01

These drawings express visual design intent only. Final engineering, materials, and fabrication shall remain the responsibility of the fabricator.

The content of this document is subject to the design intent requirements outlined in the following sections: Fabricator Performance & Material Requirements, Quantities & Submittals, Materials & Finishes, and Fonts & Symbols.

Contact:
Environmental Graphics/Wayfinding
AECOM
407-843-6552
150 N Orange Avenue, Suite 200
Orlando, Florida 32801

Project Team:
JMM
SPC
DH

Drawn By: SPC

13



14



15

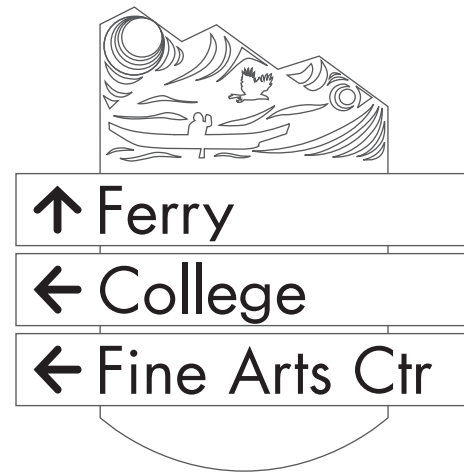

16

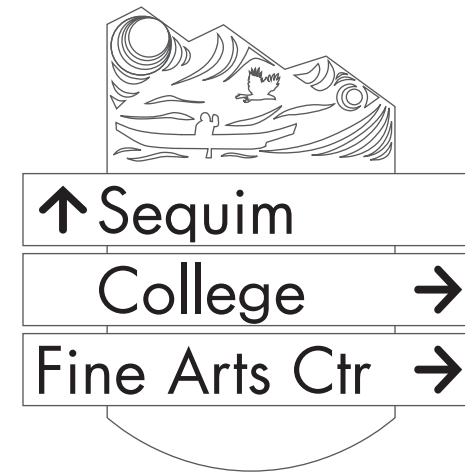

17



18



19

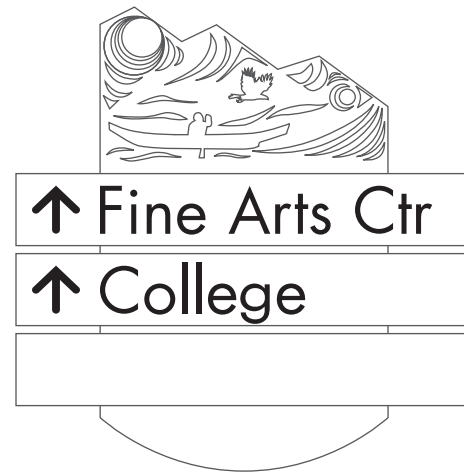

20



21



Scale: 1/2" = 1'

Note: Drawing scale shown on plans is accurate for full size plans only. AECOM is not responsible for scale discrepancies caused by reduced size plans.

Description: Sign Messages
WSDOT Vehicular Directional

Original Issue Date: 2011.01.28

Revisions: 2011.03.01

These drawings express visual design intent only. Final engineering, materials, and fabrication shall remain the responsibility of the fabricator.

The content of this document is subject to the design intent requirements outlined in the following sections: Fabricator Performance & Material Requirements, Quantities & Submittals, Materials & Finishes, and Fonts & Symbols.

Contact:
Environmental Graphics/Wayfinding
AECOM
407-843-6552
150 N Orange Avenue, Suite 200
Orlando, Florida 32801

Project Team:
JMM
SPC
DH

Drawn By: SPC

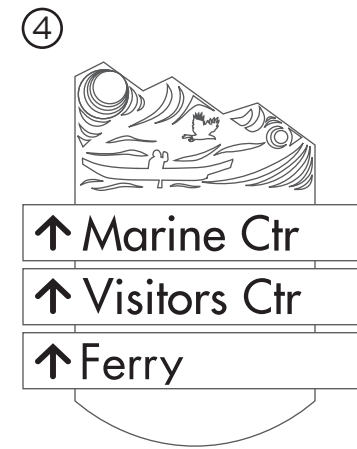
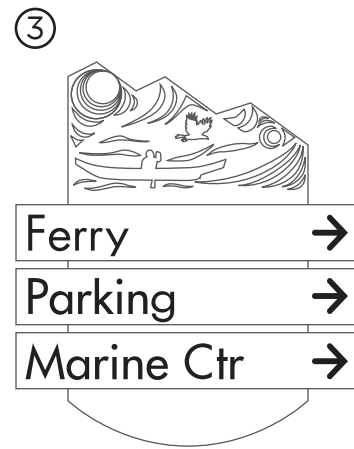

Scale: NTS

Note: Drawing scale shown on plans is accurate for full size plans only. AECOM is not responsible for scale discrepancies caused by reduced size plans.

Description: Sign Messages
Vehicular Directional

Original Issue Date: 2011.01.28

Revisions: 2011.03.01

These drawings express visual design intent only. Final engineering, materials, and fabrication shall remain the responsibility of the fabricator.

The content of this document is subject to the design intent requirements outlined in the following sections: Fabricator Performance & Material Requirements, Quantities & Submittals, Materials & Finishes, and Fonts & Symbols.

Contact:
Environmental Graphics/Wayfinding
AECOM
407-843-6552
150 N Orange Avenue, Suite 200
Orlando, Florida 32801

Project Team:
JMM
SPC
DH

Drawn By: SPC

Wayfinding System - Sign Details

Sign Messages – Sign Type B
10330217.01
City of Port Angeles, Washington

Scale: NTS

Note: Drawing scale shown on plans is accurate for full size plans only. AECOM is not responsible for scale discrepancies caused by reduced size plans.

Description: Sign Messages
Vehicular Directional

Original Issue Date: 2011.01.28

Revisions: 2011.03.10
2011.06.03

These drawings express visual design intent only. Final engineering, materials, and fabrication shall remain the responsibility of the fabricator.

The content of this document is subject to the design intent requirements outlined in the following sections: Fabricator Performance & Material Requirements, Quantities & Submittals, Materials & Finishes, and Fonts & Symbols.

Contact:
Environmental Graphics/Wayfinding
AECOM
407-843-6552
150 N Orange Avenue, Suite 200
Orlando, Florida 32801

Project Team:
JMM
SPC
DMH

Drawn By: SPC

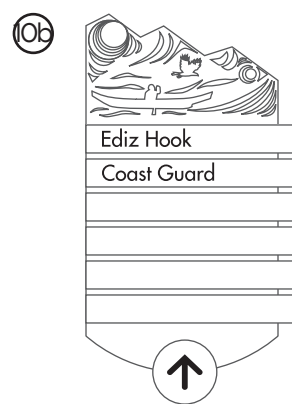
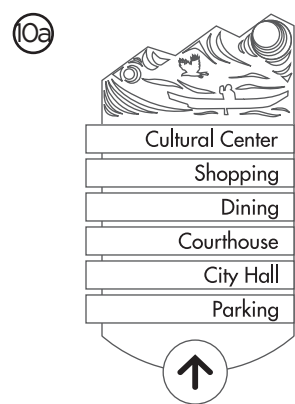
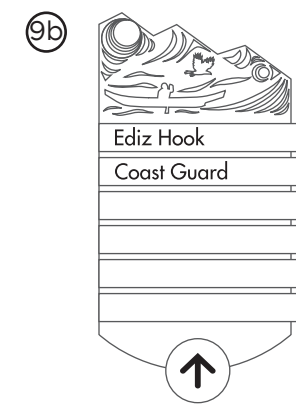
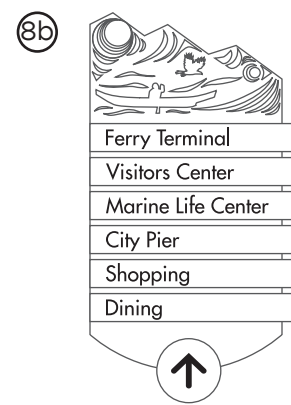
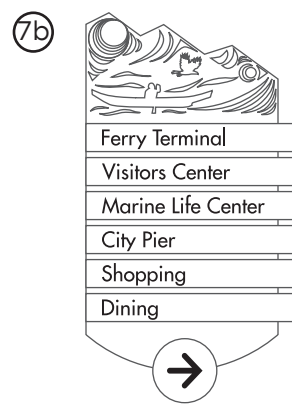
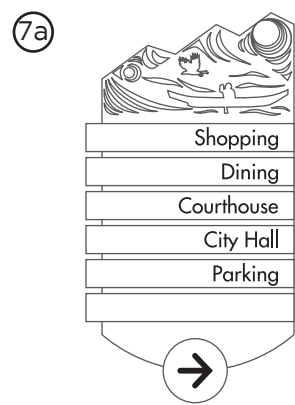
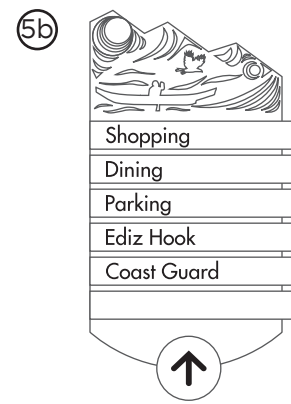
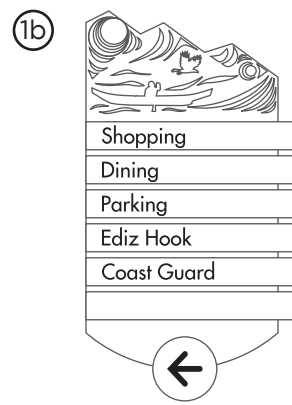
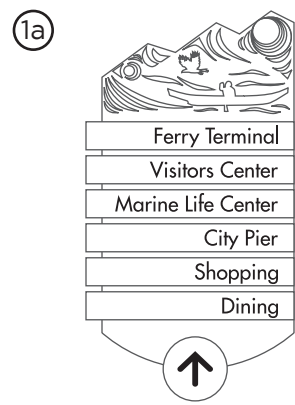

13a

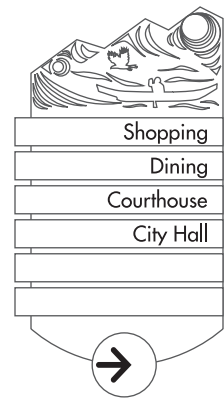

13b

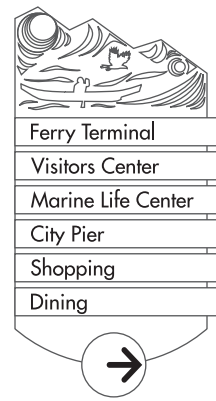

14a

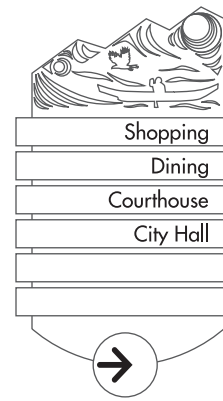

14b

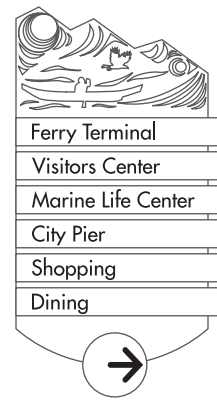

15a

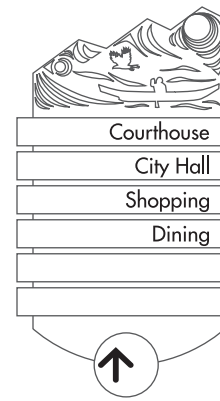

15b

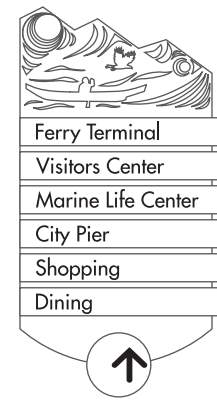

16a

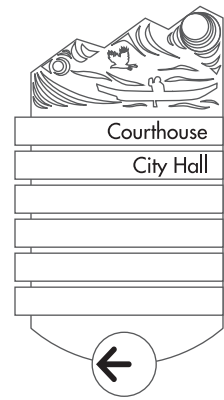

16b

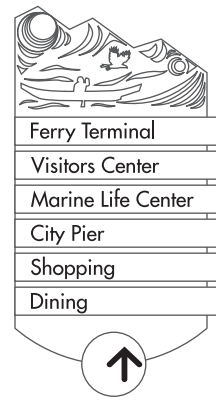

17a

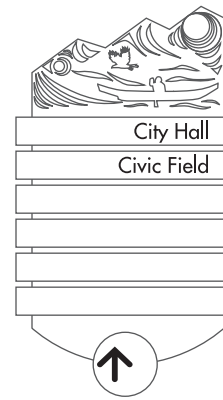

17b

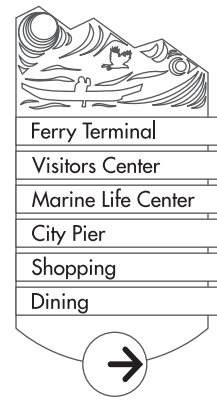

18a

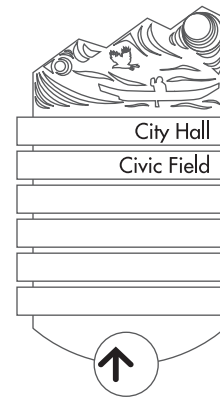

18b

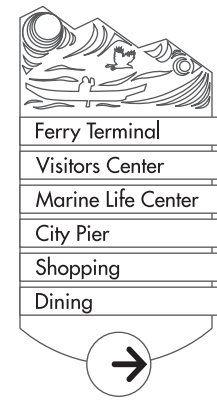

Wayfinding System - Sign Details

Sign Messages – Sign Type B
10330217.01
City of Port Angeles, Washington

Scale: NTS

Note: Drawing scale shown on plans is accurate for full size plans only. AECOM is not responsible for scale discrepancies caused by reduced size plans.

Description: Sign Messages
Vehicular Directional

Original Issue Date: 2011.01.28

Revisions: 2011.03.10
2011.06.03

These drawings express visual design intent only. Final engineering, materials, and fabrication shall remain the responsibility of the fabricator.

The content of this document is subject to the design intent requirements outlined in the following sections: Fabricator Performance & Material Requirements, Quantities & Submittals, Materials & Finishes, and Fonts & Symbols.

Contact:
Environmental Graphics/Wayfinding
AECOM
407-843-6552
150 N Orange Avenue, Suite 200
Orlando, Florida 32801

Project Team:
JMM
SPC
DMH

Drawn By: SPC

Wayfinding System - Sign Details

Sign Messages – Sign Type D-2
10330217.01
City of Port Angeles, Washington

Scale: NTS

Note: Drawing scale shown on plans is accurate for full size plans only. AECOM is not responsible for scale discrepancies caused by reduced size plans.

Description: Sign Messages
Parking ID with Map

Original Issue Date: 2011.01.28

Revisions: 2011.03.12
2011.06.06

These drawings express visual design intent only. Final engineering, materials, and fabrication shall remain the responsibility of the fabricator.

The content of this document is subject to the design intent requirements outlined in the following sections: Fabricator Performance & Material Requirements, Quantities & Submittals, Materials & Finishes, and Fonts & Symbols.

Contact:
Environmental Graphics/Wayfinding
AECOM
407-843-6552
150 N Orange Avenue, Suite 200
Orlando, Florida 32801

Project Team:
JMM
SPC
DMH

Drawn By: SPC

①

PARKING

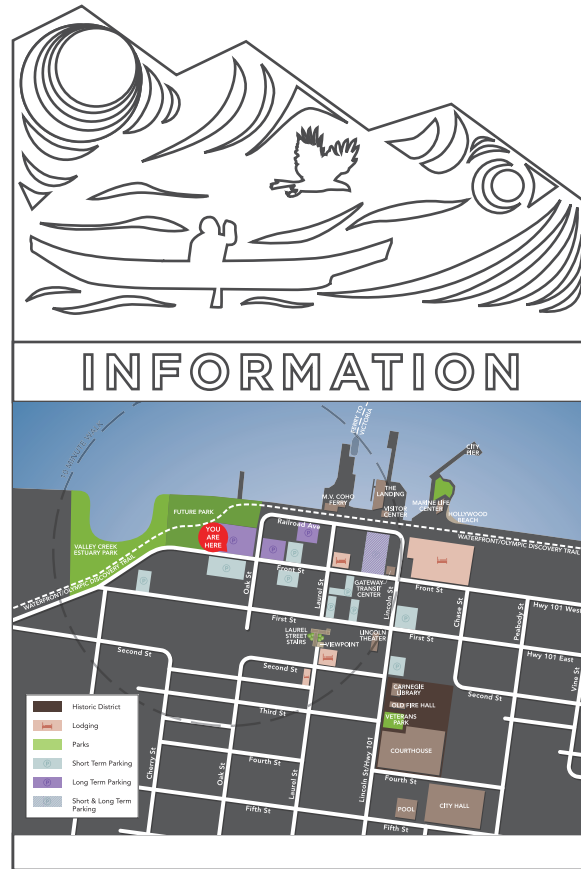

②

PARKING

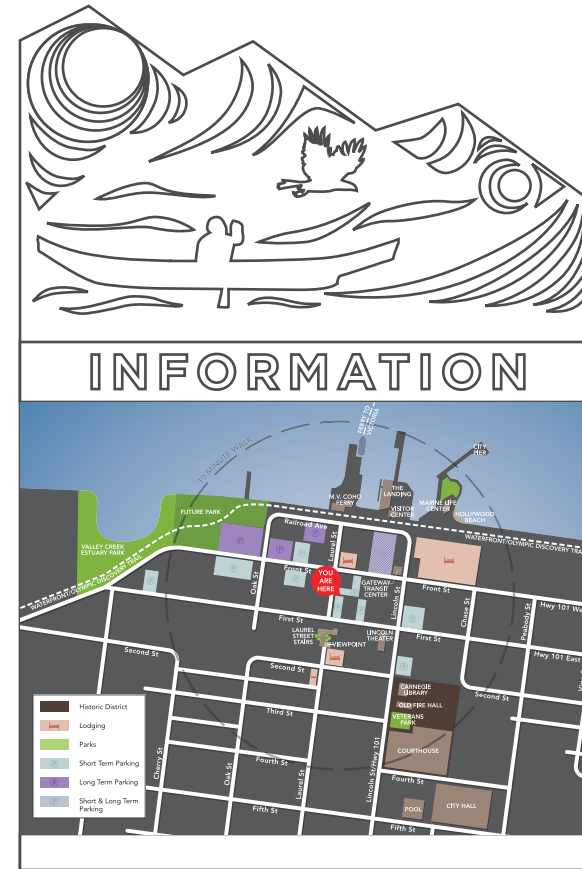

③

PARKING

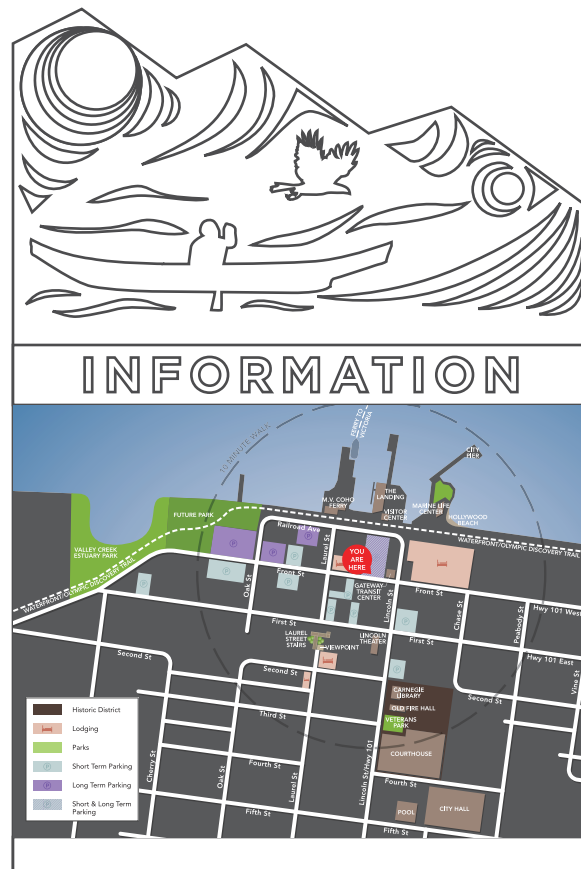

④

PARKING

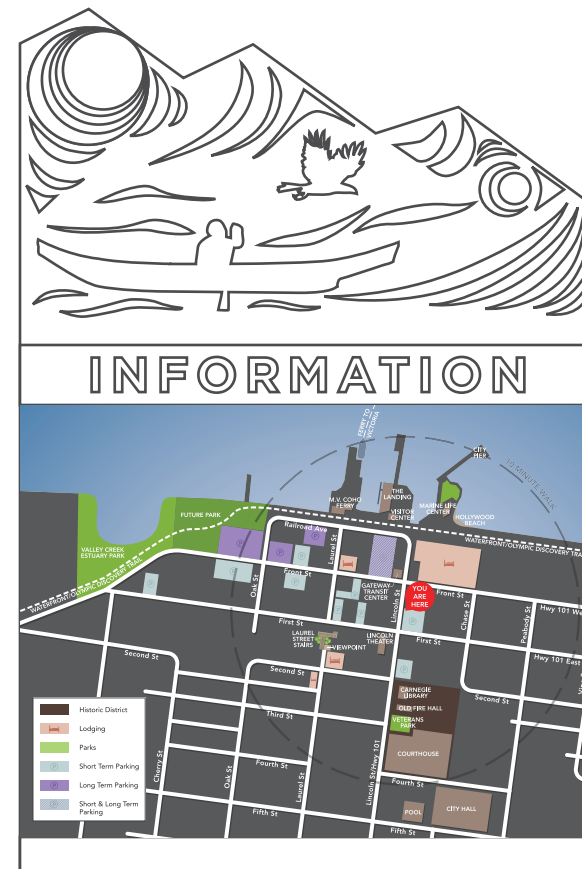

Wayfinding System - Sign Details

Sign Messages – Sign Type E
10330217.01
City of Port Angeles, Washington

Scale: NTS

Note: Drawing scale shown on plans is accurate for full size plans only. AECOM is not responsible for scale discrepancies caused by reduced size plans.

Description: Sign Messages
Pedestrian Kiosk Map

Original Issue Date: 2011.01.28

Revisions: 2011.03.01
2011.06.06

These drawings express visual design intent only. Final engineering, materials, and fabrication shall remain the responsibility of the fabricator.

The content of this document is subject to the design intent requirements outlined in the following sections: Fabricator Performance & Material Requirements, Quantities & Submittals, Materials & Finishes, and Fonts & Symbols.

Contact:
Environmental Graphics/Wayfinding
AECOM
407-843-6552
150 N Orange Avenue, Suite 200
Orlando, Florida 32801

Project Team:
JMM
SPC
DMH

Drawn By: SPC

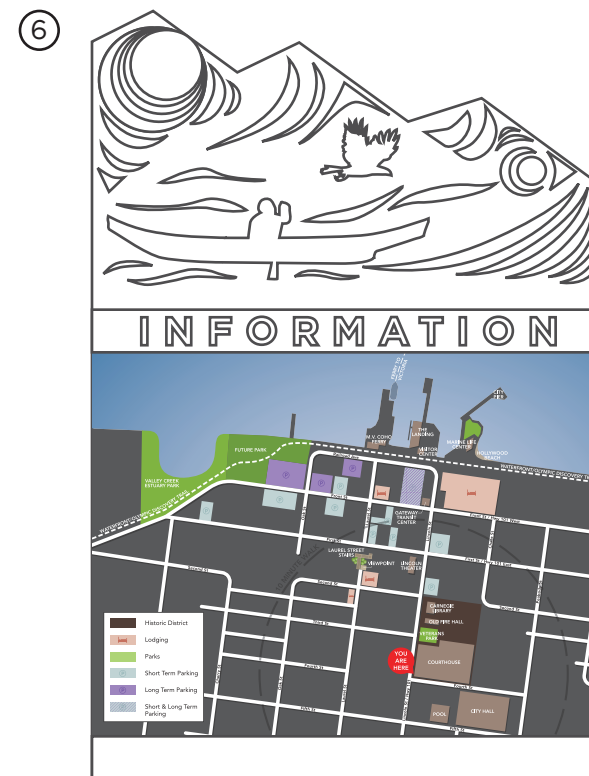
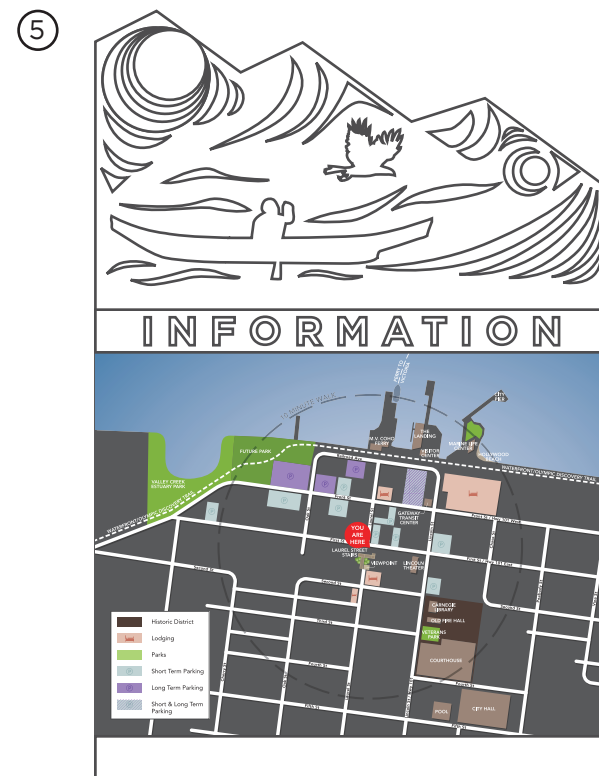
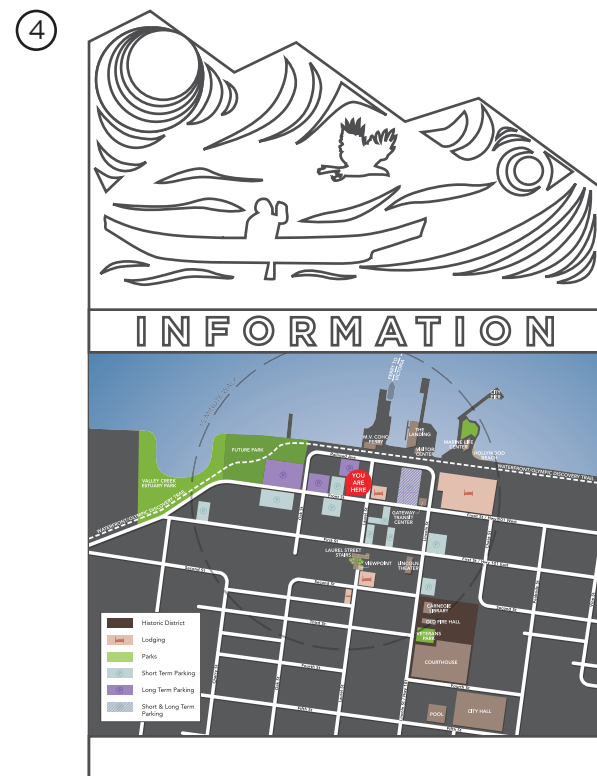
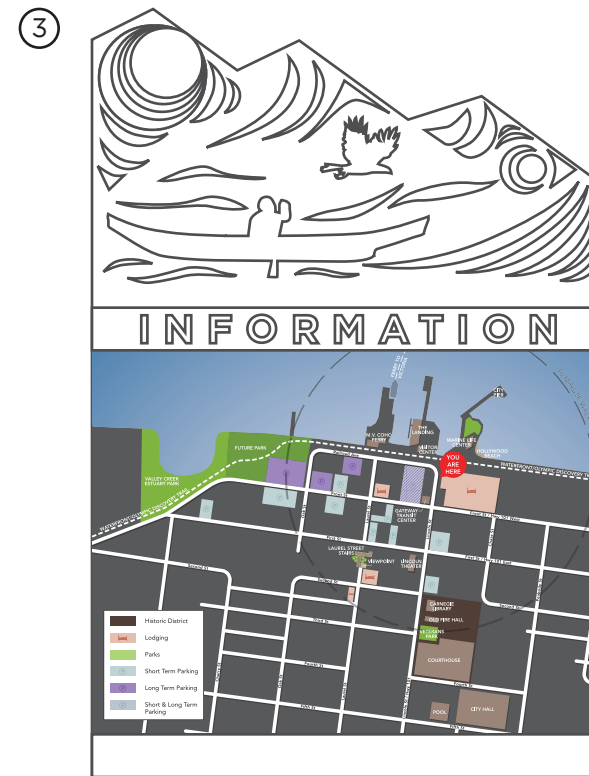
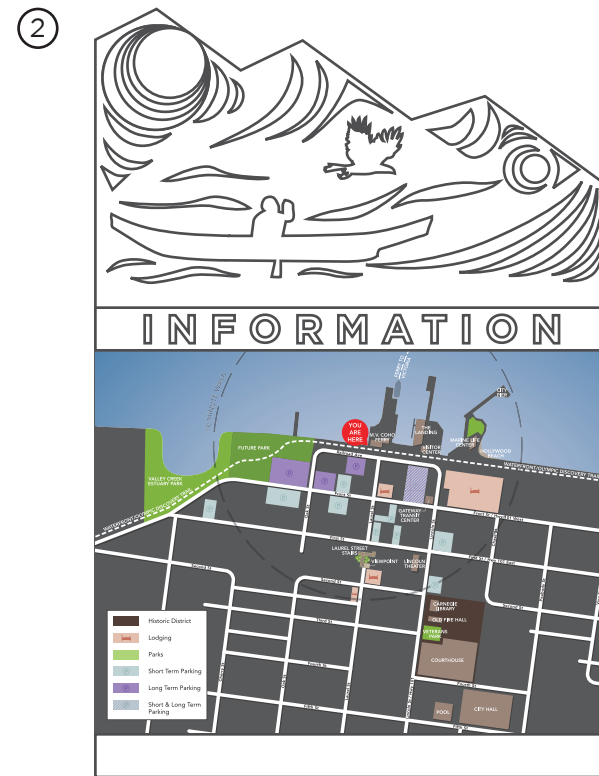
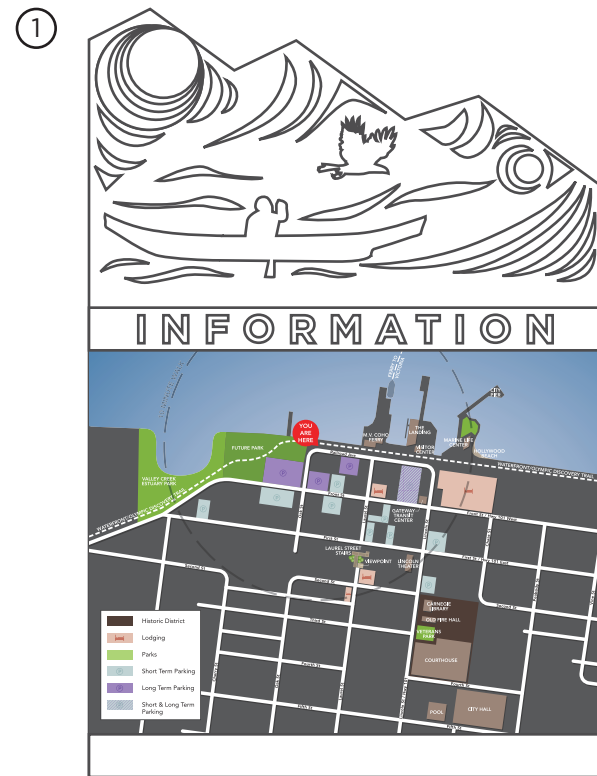

Wayfinding System - Sign Details

Sign Messages – Sign Type G-2
10330217.01
City of Port Angeles, Washington

Scale: NTS

Note: Drawing scale shown on plans is accurate for full size plans only. AECOM is not responsible for scale discrepancies caused by reduced size plans.

Description: Sign Messages
Tsunami Evacuation Route Directional

Original Issue Date: 2011.01.28

Revisions: 2011.03.01
2011.06.14

These drawings express visual design intent only. Final engineering, materials, and fabrication shall remain the responsibility of the fabricator.

The content of this document is subject to the design intent requirements outlined in the following sections: Fabricator Performance & Material Requirements, Quantities & Submittals, Materials & Finishes, and Fonts & Symbols.

Contact:
Environmental Graphics/Wayfinding
AECOM
407-843-6552
150 N Orange Avenue, Suite 200
Orlando, Florida 32801

Project Team:
JMM
SPC
DMH

Drawn By: SPC

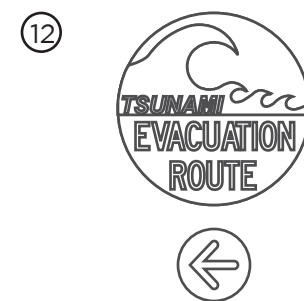
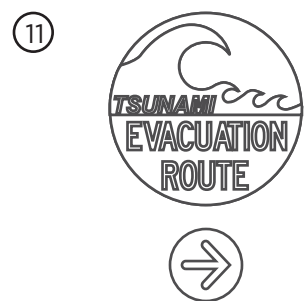
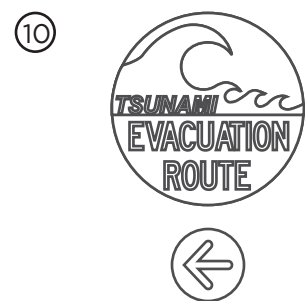
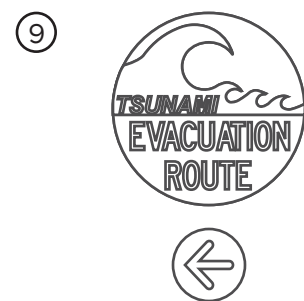
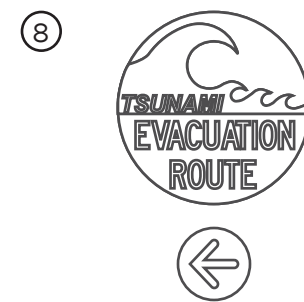
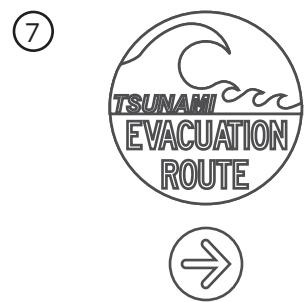
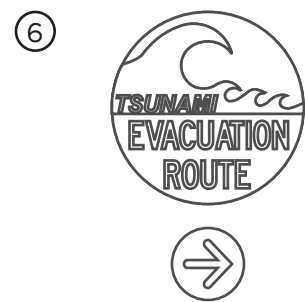
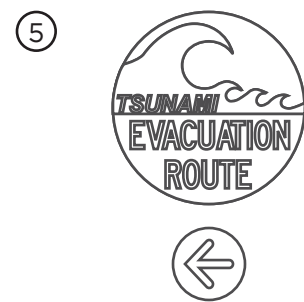
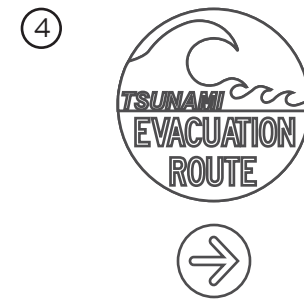
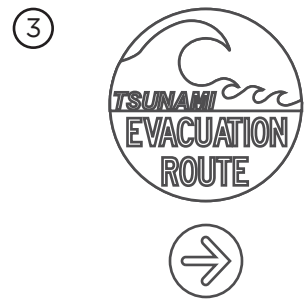
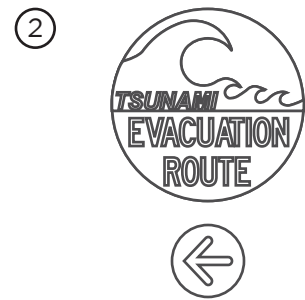
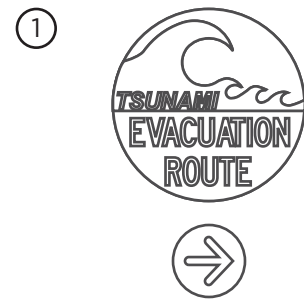

Wayfinding System - Sign Details

Sign Messages – Prototypes
10330217.01
City of Port Angeles, Washington

Scale: NTS

Note: Drawing scale shown on plans is accurate for full size plans only. AECOM is not responsible for scale discrepancies caused by reduced size plans.

Description: Sign Messages
Prototypes

Original Issue Date: 2011.01.28

Revisions: 2011.02.28 2011.06.06
2011.03.10
2011.03.11

These drawings express visual design intent only. Final engineering, materials, and fabrication shall remain the responsibility of the fabricator.

The content of this document is subject to the design intent requirements outlined in the following sections: Fabricator Performance & Material Requirements, Quantities & Submittals, Materials & Finishes, and Fonts & Symbols.

Contact:
Environmental Graphics/Wayfinding
AECOM
407-843-6552
150 N Orange Avenue, Suite 200
Orlando, Florida 32801

Project Team:
JMM
SPC
DMH

Drawn By: SPC

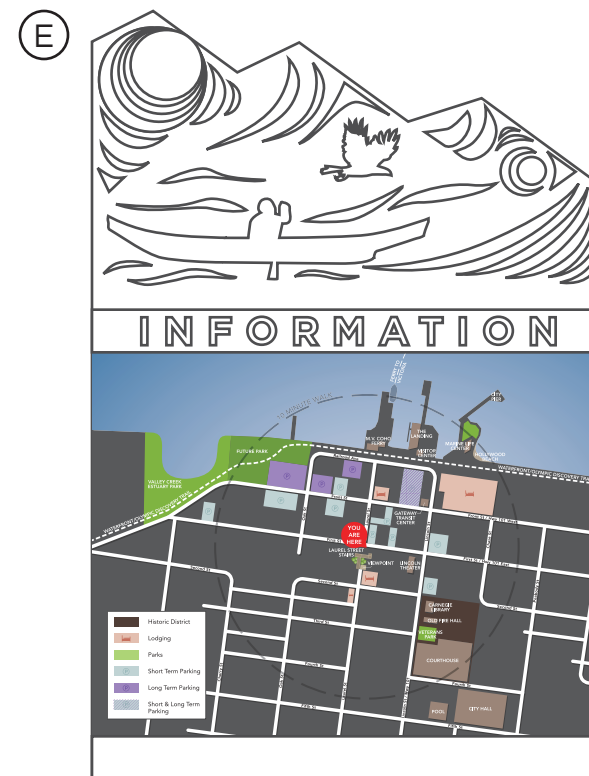
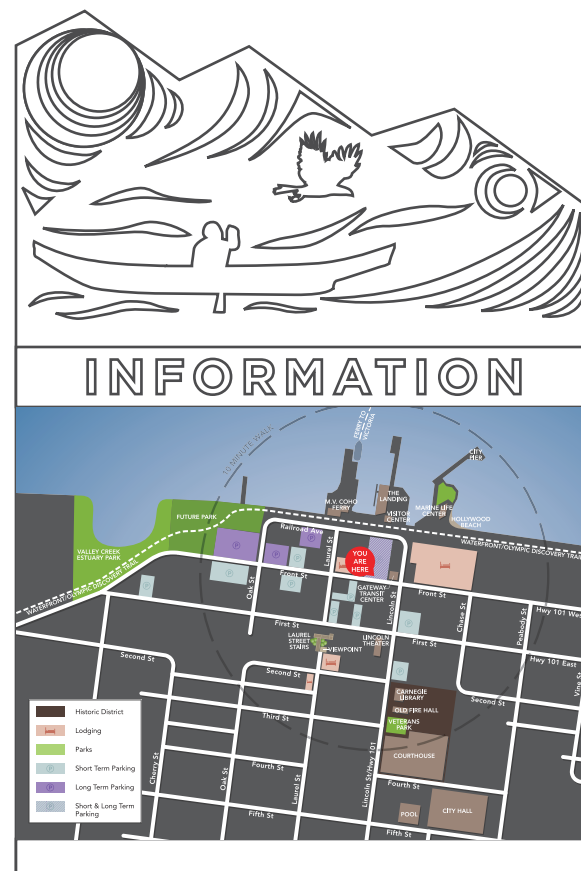
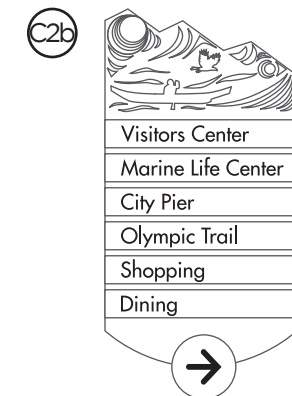
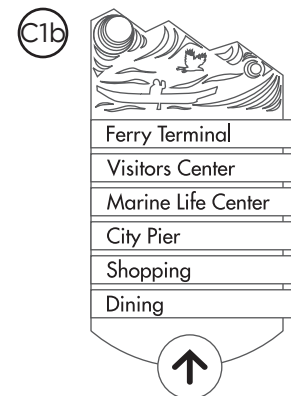
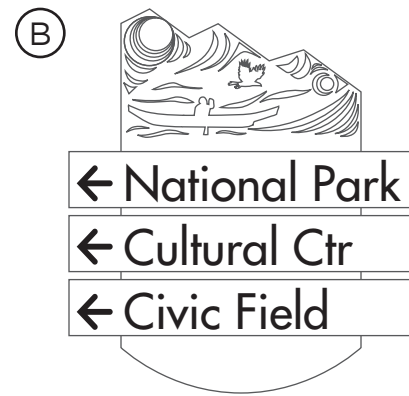

Wayfinding System - Sign Details

Sign Quantities
 10330217.01
 City of Port Angeles, Washington

Scale: NTS

Note: Drawing scale shown on plans is accurate for full size plans only. AECOM is not responsible for scale discrepancies caused by reduced size plans.

Description:
 Sign Quantities

Original Issue Date: 2011.01.07

Revisions: 2011.01.25
 2011.03.16
 2011.06.14

These drawings express visual design intent only. Final engineering, materials, and fabrication shall remain the responsibility of the fabricator.

The content of this document is subject to the design intent requirements outlined in the following sections: Fabricator Performance & Material Requirements, Quantities & Submittals, Materials & Finishes, and Fonts & Symbols.

Contact:
 Environmental Graphics/Wayfinding
 AECOM
 407-843-6552
 150 N Orange Avenue, Suite 200
 Orlando, Florida 32801

Project Team:
 JMM
 SPC
 DMH

Drawn By: SPC

Sign Type	Description	Quantity
A	WSDOT Vehicular Directional	21
B	Small Vehicular Directional	9
C	Pedestrian Directional	18
D-1	Parking ID	6
D-2	Parking ID with Map	4
E	Pedestrian Kiosk Map	6
F	Historic District	3
G-1	Tsunami Evacuation Route ID	7
G-2	Tsunami Evacuation Route Directional	12

TIPS FOR SUCCESS

Management and Maintenance

Management can be handled through the establishment of a governing body that oversees the funding, maintenance, and expansion of the sign program. A project manager should be assigned the responsibility of day to day management of the system. Maintenance should be the shared responsibility of the City and the program's Stakeholders.

It is recommended that the City should have a higher-level professional cleaning program in place. Panels in high sun or tougher areas should be coated with a film, (Tedlar, mylar) to protect against ultraviolet rays. Cleaning should be carefully done with Goof Off or Goo Gone for stickers, and a mild paint thinner for graffiti. Professionals or highly trained staff should complete panel cleaning.

Special Considerations

In-house fabrication will likely be limited to graphics and lettering for changing messages, poles, foundations, and installation. Initial "attic stock" of parts should be included in the base bid of each phase of the project. Attic stock can include poles (painted), sign panels (painted/no lettering), brackets finished and painted and other parts.

Best Cleaning Practices

Maintenance Schedule: Signs should be cleaned at least annually, twice a year is preferred.

Dirt and Grime: Use a mix of Simple Green and water.

Removing Graffiti: Use a Mild Enamel Thinner.

Removing Stickers: Recommended products are Goof Off and/or Goo Gone.

New Sign Types

Any additional sign types shall be designed to be consistent with the design of the wayfinding system. This includes color, materials and overall aesthetics.

Priority for Sign Installation and Removal

If the system needs to be installed in phases, it is recommended that complete sign types be installed and not a combination of sign types. This will be the most effective way of providing a complete route from route to destination.

Removal of existing signage should happen simultaneously or before (as close as possible) installation of the new signs. This will ensure that some level of direction or guidance is in place while the system is being installed.

GENERAL MAINTENANCE

Short Term General Maintenance (0 – 4 Years)

Planning and Design Minor corrections and adjustments help the system operate efficiently. This may include additional signs, or adjustments based on new circulation patterns.

Physical Maintenance (Materials) Annual cleaning and typical maintenance (wear and tear repairs) – new panels, tightening of fasteners, replacement parts due to vandalism or auto damage.

Physical Maintenance (Locations) Relocation may be necessary based on problem sign locations.

Long Term General Maintenance (5 – 9 years)

Planning and Design Additions and deletions of destinations and/or messages and overall routing review may be necessary, based on physical changes to the City.

Physical Maintenance (Materials) Materials begin to fade, warranties expire (Avery vinyl is warranted for 7 years) and a more concentrated effort is required to maintain the system. New panels, replacement parts, and sign replacement may be necessary.

Physical Maintenance (Locations) Relocation may be necessary based on new routing or circulation.

System Life Span (10 – 15+ years)

Planning and Design Complete review of the system and its effectiveness based on new destinations that may have opened or attractions which have closed. In addition, new circulation/routing and construction projects may effect the system. Design elements may be reviewed for consistency with City identity and marketing initiatives.

Physical Maintenance (Materials) Materials begin to reach their life span, full sign replacement may be necessary for some signs if they have not been maintained in the past.

Physical Maintenance (Locations) Relocation may be necessary based on new routing or circulation.

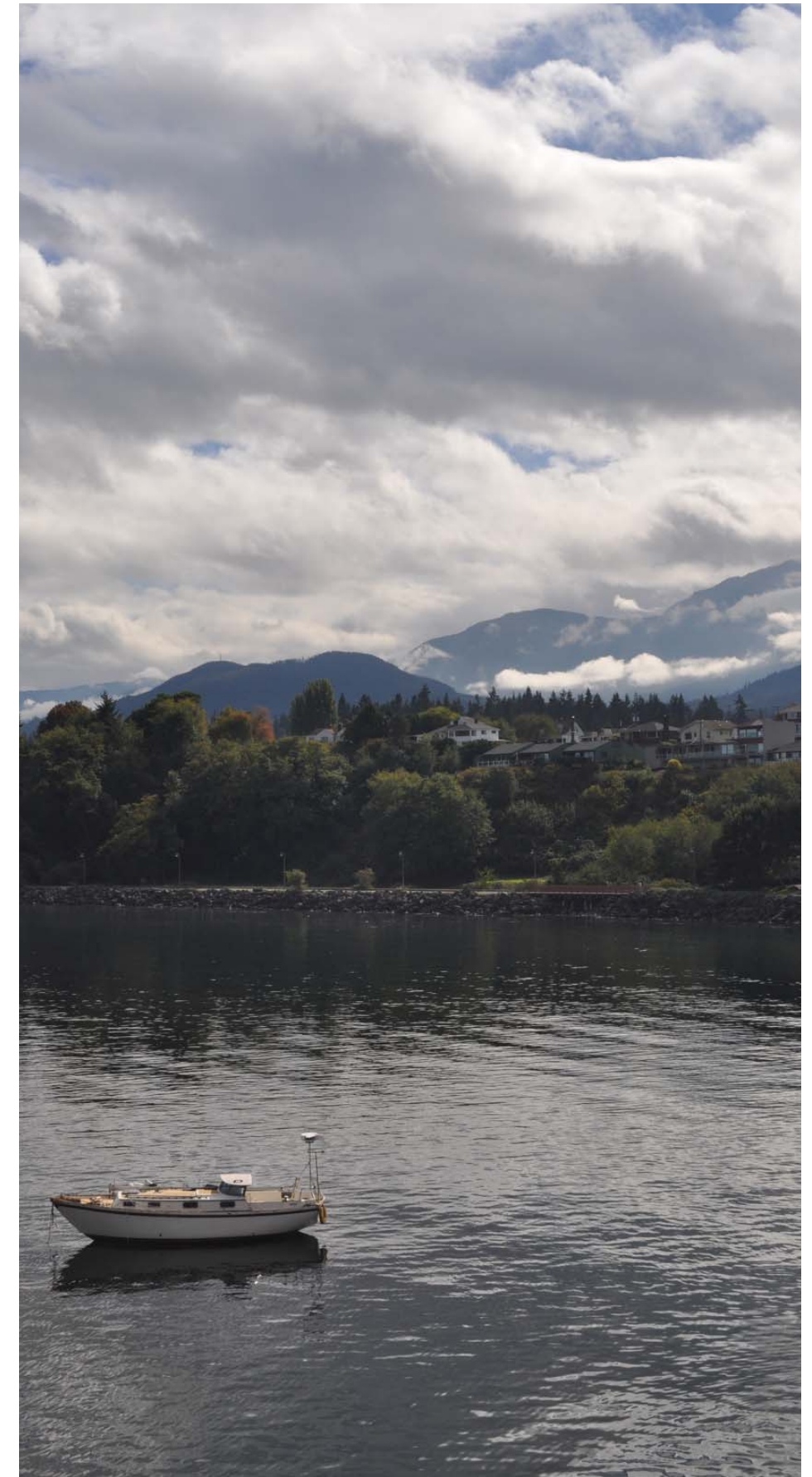



AECOM

